

BIDDING DOCUMENTS

ITB 2020-075

LOT 1

Supply and Delivery of Materials for DPWH
Pole Relocation Project within the Coverage
Area of Camarines Norte Electric Cooperative,
Inc. (CANORECO)

29 October 2020
Daet, Camarines Norte

TABLE OF CONTENTS

SECTION I. INVITATION TO BID	3
SECTION II. INSTRUCTION TO BIDDERS	7
SECTION III. BID DATA SHEET	38
SECTION IV. GENERAL CONDITIONS OF CONTRACT	42
SECTION V. SPECIAL CONDITIONS OF CONTRACT	59
SECTION VI. SCHEDULE OF REQUIREMENTS	65
SECTION VII. TECHNICAL SPECIFICATIONS	69
SECTION VIII. BIDDING FORMS	104

Section I. Invitation to Bid

CAMARINES NORTE ELECTRIC COOPERATIVE, INC.
Jose P. Rizal St., Daet, Camarines Norte

INVITATION TO BID NO. ITB 2020-075

The Camarines Norte Electric Cooperative, Inc. (CANORECO) through its Bids and Awards Committee (BAC) invites all bidders to bid for below requirements.

LOT	Project Description	Approved Budget for the Contract (inclusive of VAT)	Cost of Bidding Documents
1	Supply and Delivery of Materials for DPWH Pole Relocation Project	PHP 33,929,179.00	PHP 25,000.00

Approved Budget is based on NEA's Equipment / Material Price Index 2019.
 Source of Fund: *DPWH Fund*

Calendar of Activities:

<u>ACTIVITIES</u>	<u>SCHEDULE</u>
Advertisement/Posting of Invitation To Bid Form	October 20, 2020 (Tuesday)
Bidding Requirements Distribution	October 20, 2020 – November 09, 2020 (1:59 P.M.)
Pre-Bid Conference	October 29, 2020 (Thursday) 2:00 pm via Zoom Meeting
Deadline of Bid Submission & Receipts of Bids/Bid Opening	November 09, 2020 (Monday) 2:00 pm via Zoom Meeting

All aspects of the bidding process shall be based entirely on the 2016 Revised Implementing Rules and Regulations of Republic Act No. 9184.

Representatives of bidders who will attend the Pre-bid Conference and Bid Opening must have duly notarized authorization.

The CANORECO reserves the right to accept or reject any bid, to cancel the bidding process and to reject all bids at any time prior to contract award, without thereby incurring any liability to the affected bidders.

For other details and concerns, please inquire in person at CANORECO Main Office, Daet, Camarines Norte through the BAC Secretariat or you may send an e-mail at canoreco_197505@yahoo.com / canoreco_bac1975@yahoo.com.ph.

Issued by:

MARY ANN A. MORENO
 Chairperson

Noted by:

ZANDRO R. GESTIADA
 General Manager

CAMARINES NORTE ELECTRIC COOPERATIVE, INC.

Jose P. Rizal St., Brgy. IDaet, Camarines Norte

HOTLINE: (054) 571-3717 and (054) 571-3796

Email Add: canoreco_197505@yahoo.com

Invitation to Bid No. 2020-075

(Supply and Delivery of Materials for DPWH Pole Relocation Project within the Coverage Area of CANORECO)

1. The **CANORECO**, through the **DPWH's fund** intends to apply the sum of **Thirty-three Million Nine Hundred Twenty-nine Thousand One Hundred Seventy-nine Pesos only(Php33,929,179.00)** being the Approved Budget for the Contract (ABC). Bids received in excess of the ABC for each lot shall be automatically rejected during bid opening.
2. The **CANORECO** now invites bids for **Supply and Delivery of Materials for DPWH Pole Relocation Project within the Coverage Area of CANORECO**. Delivery of the Goods is required **sixty (60) calendar days** upon issuance of Notice to Proceed. Bidders should have completed, within **five (5) years** from the date of submission and receipt of bids, a contract similar to the Project. The description of an eligible bidder is contained in the Bidding Documents, particularly in Section II. Instructions to Bidders.
3. Bidding will be conducted through open competitive bidding procedures using a non-discretionary "pass/fail" criterion as specified in the 2016 Revised Implementing Rules and Regulations (IRR) of Republic Act (RA) 9184, otherwise known as the "Government Procurement Reform Act".

Bidding is restricted to Filipino citizens/sole proprietorships, partnerships, or organizations with at least sixty percent (60%) interest or outstanding capital stock belonging to citizens of the Philippines, and to citizens or organizations of a country the laws or regulations of which grant similar rights or privileges to Filipino citizens, pursuant to RA 5183.
4. Interested bidders may obtain further information from **CANORECO** and inspect the Bidding Documents at the address given below during **October 20, 2020 (8:00 AM-5:00 PM) until 8:59 AM of September 01, 2020 only**.
5. A complete set of Bidding Documents may be acquired by interested Bidders on **August 13, 2020(8:00 AM-5:00 PM) until 1:59 PM of November 09, 2020 only** from the address below and upon payment of **Twenty-five Thousand Pesos (Php25,000.00)**.
6. The **CANORECO** shall hold a **Pre-Bid Conference on October 29, 2020 Thursday2:00pm at CANORECO Main Office Board Room via ZOOM**, which shall be open to all prospective bidders.

7. Bids must be duly received by the BAC Secretariat at the address below on or before **1:59 PM of November 09, 2020**. All Bids must be accompanied by a bid security in any of the acceptable forms and in the amount stated in **ITB** Clause 18.

Bid opening shall be on **November 09, 2020, 2:00 PM** at **CANORECO Main office, 3rd floor Board Room, J.P Rizal St., Brgy. 1, Daet, Camarines Norte** **via ZOOM**. Interested bidders will be required to submit authorization allowing the Bids and Awards Committee (BAC) to conduct actual bid opening of their submitted Eligibility Requirements and Bid Proposal without their presence and **via ZOOM Meeting**. This is in observance and compliance with the current precautionary measures being implemented by the government.

8. All aspects of the bidding process shall be based entirely on the 2016 Revised Implementing Rules and Regulations of Republic Act No. 9184.

Representatives of bidders who will attend the Bid Opening via Zoom Meeting must forward an advance copy of an authorization duly notarized and signed by the owner/manager of the company.

For other details and concerns, please inquire in person at the Main Office of Camarines Norte Electric Cooperative, Inc. (CANORECO), Daet, Camarines Norte through the BAC Secretariat or you may send an e-mail at **canoreco 197505@yahoo.com** / **canoreco_bac1975@yahoo.com.ph**

9. The **CANORECO** reserves the right to reject any and all bids, declare a failure of bidding, or not award the contract at any time prior to contract award in accordance with Section 41 of RA 9184 and its IRR, without thereby incurring any liability to the affected bidder or bidders.

MARY ANN A. MORENO
BAC Chairperson

Section II. Instructions to Bidders

TABLE OF CONTENTS

A. GENERAL	10
1. Scope of Bid	10
2. Source of Funds	10
3. Corrupt, Fraudulent, Collusive and Coercive Practices	10
4. Conflict of Interest	12
5. Eligible Bidders	13
6. Bidder's Responsibilities	14
7. Origin of Goods	17
8. Subcontracts	17
B. Contents of bidding documents	17
9. Pre-Bid Conference	17
10. Clarification and Amendment of Bidding Documents	18
C. PREPARATION OF BIDS	18
11. Language of Bid	18
12. Documents Comprising the Bid: Eligibility and Technical Components	19
13. Documents Comprising the Bid: Financial Component	21
14. Alternative Bids	21
15. Bid Prices	22
16. Bid Currencies	23
17. Bid Validity	24
18. Bid Security	24
19. Format and Signing of Bids	26
20. Sealing and Marking of Bids	27
D. SUBMISSION AND OPENING OF BIDS	28
21. Deadline for Submission of Bids	28
22. Late Bids	28
23. Modification and Withdrawal of Bids	28
24. Opening and Preliminary Examination of Bids	29
E. EVALUATION AND COMPARISON OF BIDS	30
25. Process to be Confidential	30
26. Clarification of Bids	30
27. Domestic Preference	31
28. Detailed Evaluation and Comparison of Bids	31
29. Post-Qualification	32

30.Reservation Clause	34
F. AWARD OF CONTRACT	35
31.Contract Award	35
32.Signing of the Contract	35
33.Performance Security.....	36
34.Notice to Proceed	37
35.Protest Mechanism	37

A. General

1. Scope of Bid

- 1.1. The Procuring Entity named in the **BDS** invites bids for the supply and delivery of the Goods as described in Section VII. Technical Specifications
- 1.2. The name, identification, and number of lots specific to this bidding are provided in the **BDS**. The contracting strategy and basis of evaluation of lots is described in **ITB** Clause 28.

2. Source of Funds

The Procuring Entity has a budget or has received funds from the Funding Source named in the **BDS**, and in the amount indicated in the **BDS**. It intends to apply part of the funds received for the Project, as defined in the **BDS**, to cover eligible payments under the contract.

3. Corrupt, Fraudulent, Collusive, and Coercive Practices

- 3.1. Unless otherwise specified in the **BDS**, the Procuring Entity as well as the bidders and suppliers shall observe the highest standard of ethics during the procurement and execution of the contract. In pursuance of this policy, the Procuring Entity:
 - (a) defines, for purposes of this provision, the terms set forth below as follows:
 - (i) “corrupt practice” means behaviour on the part of officials in the public or private sectors by which they improperly and unlawfully enrich themselves, others, or induce others to do so, by misusing the position in which they are placed, and includes the offering, giving, receiving, or soliciting of anything of value to influence the action of any such official in the procurement process or in contract execution; entering, on behalf of the government, into any contract or transaction manifestly and grossly disadvantageous to the same, whether or not the public officer profited or will profit thereby, and similar acts as provided in RA 3019.
 - (ii) “fraudulent practice” means a misrepresentation of facts in order to influence a procurement process or the execution of a contract to the detriment of the Procuring Entity, and includes collusive practices among Bidders (prior to or after bid submission) designed to establish bid prices at artificial, non-competitive levels and to deprive the Procuring Entity of the benefits of free and open competition.

- (iii) “collusive practices” means a scheme or arrangement between two or more Bidders, with or without the knowledge of the Procuring Entity, designed to establish bid prices at artificial, non-competitive levels.
- (iv) “coercive practices” means harming or threatening to harm, directly or indirectly, persons, or their property to influence their participation in a procurement process, or affect the execution of a contract;
- (v) “obstructive practice” is
 - (aa) deliberately destroying, falsifying, altering or concealing of evidence material to an administrative proceedings or investigation or making false statements to investigators in order to materially impede an administrative proceedings or investigation of the Procuring Entity or any foreign government/foreign or international financing institution into allegations of a corrupt, fraudulent, coercive or collusive practice; and/or threatening, harassing or intimidating any party to prevent it from disclosing its knowledge of matters relevant to the administrative proceedings or investigation or from pursuing such proceedings or investigation; or
 - (bb) acts intended to materially impede the exercise of the inspection and audit rights of the Procuring Entity or any foreign government/foreign or international financing institution herein.
- (b) will reject a proposal for award if it determines that the Bidder recommended for award has engaged in any of the practices mentioned in this Clause for purposes of competing for the contract.

3.2. Further, the Procuring Entity will seek to impose the maximum civil, administrative, and/or criminal penalties available under applicable laws on individuals and organizations deemed to be involved in any of the practices mentioned in **ITB** Clause 3.1(a).

3.3. Furthermore, the Funding Source and the Procuring Entity reserve the right to inspect and audit records and accounts of a bidder or supplier in the bidding for and performance of a contract themselves or through independent auditors as reflected in the **GCC** Clause3.

4. Conflict of Interest

4.1. All Bidders found to have conflicting interests shall be disqualified to participate in the procurement at hand, without prejudice to the imposition of appropriate administrative, civil, and criminal sanctions. A Bidder may be considered to have conflicting interests with another Bidder in any of the events described in paragraphs (a) through (c) below and a general conflict of interest in any of the circumstances set out in paragraphs (d) through (g) below:

- (a) A Bidder has controlling shareholders in common with another Bidder;
- (b) A Bidder receives or has received any direct or indirect subsidy from any other Bidder;
- (c) A Bidder has the same legal representative as that of another Bidder for purposes of this bid;
- (d) A Bidder has a relationship, directly or through third parties, that puts them in a position to have access to information about or influence on the bid of another Bidder or influence the decisions of the Procuring Entity regarding this bidding process;
- (e) A Bidder submits more than one bid in this bidding process. However, this does not limit the participation of subcontractors in more than one bid;
- (f) A Bidder who participated as a consultant in the preparation of the design or technical specifications of the Goods and related services that are the subject of the bid; or
- (g) A Bidder who lends, or temporarily seconds, its personnel to firms or organizations which are engaged in consulting services for the preparation related to procurement for or implementation of the project, if the personnel would be involved in any capacity on the same project.

4.2. In accordance with Section 47 of the IRR of RA 9184, all Bidding Documents shall be accompanied by a sworn affidavit of the Bidder that it is not related to the Head of the Procuring Entity (HoPE), members of the Bids and Awards Committee (BAC), members of the Technical Working Group (TWG), members of the BAC Secretariat, the head of the Project Management Office (PMO) or the end-user unit, and the project consultants, by consanguinity or affinity up to the third civil degree. On the part of the Bidder, this Clause shall apply to the following persons:

- (a) If the Bidder is an individual or a sole proprietorship, to the Bidder himself;
- (b) If the Bidder is a partnership, to all its officers and members;
- (c) If the Bidder is a corporation, to all its officers, directors, and controlling stockholders;

- (d) If the Bidder is a cooperative, to all its officers, directors, and controlling shareholders or members; and
- (e) If the Bidder is a joint venture (JV), the provisions of items (a), (b), (c), or (d) of this Clause shall correspondingly apply to each of the members of the said JV, as may be appropriate.

Relationship of the nature described above or failure to comply with this Clause will result in the automatic disqualification of a Bidder.

5. Eligible Bidders

5.1. Unless otherwise provided in the **BDS**, the following persons shall be eligible to participate in this bidding:

- (a) Duly licensed Filipino citizens/sole proprietorships;
- (b) Partnerships duly organized under the laws of the Philippines and of which at least sixty percent (60%) of the interest belongs to citizens of the Philippines;
- (c) Corporations duly organized under the laws of the Philippines, and of which at least sixty percent (60%) of the outstanding capital stock belongs to citizens of the Philippines;
- (d) Cooperatives duly organized under the laws of the Philippines; and
- (e) Persons/entities forming themselves into a Joint Venture (JV), *i.e.*, a group of two (2) or more persons/entities that intend to be jointly and severally responsible or liable for a particular contract: Provided, however, that Filipino ownership or interest of the JV concerned shall be at least sixty percent (60%).

5.2. Foreign bidders may be eligible to participate when any of the following circumstances exist, as specified in the **BDS**:

- (a) When a Treaty or International or Executive Agreement as provided in Section 4 of RA 9184 and its IRR allow foreign bidders to participate;
- (b) Citizens, corporations, or associations of a country, the laws or regulations of which grant reciprocal rights or privileges to citizens, corporations, or associations of the Philippines;
- (c) When the Goods sought to be procured are not available from local suppliers; or
- (d) When there is a need to prevent situations that defeat competition or restrain trade.

- 5.3. Government owned or –controlled corporations (GOCCs) may be eligible to participate only if they can establish that they (a) are legally and financially autonomous, (b) operate under commercial law, and (c) are not attached agencies of the Procuring Entity.
- 5.4. Unless otherwise provided in the **BDS**, the Bidder must have completed a Single Largest Completed Contract (SLCC) similar to the Project and the value of which, adjusted, if necessary, by the Bidder to current prices using the Philippine Statistics Authority (PSA) consumer price index, must be at least equivalent to a percentage of the ABC stated in the **BDS**.

For this purpose, contracts similar to the Project shall be those described in the **BDS**, and completed within the relevant period stated in the Invitation to Bid and **ITB** Clause 12.1(a)(ii).

- 5.5. The Bidder must submit a computation of its Net Financial Contracting Capacity (NFCC), which must be at least equal to the ABC to be bid, calculated as follows:

NFCC = [(Current assets minus current liabilities) (15)] minus the value of all outstanding or uncompleted portions of the projects under on-going contracts, including awarded contracts yet to be started, coinciding with the contract to be bid.

The values of the domestic bidder’s current assets and current liabilities shall be based on the latest Audited Financial Statements submitted to the BIR.

For purposes of computing the foreign bidders’ NFCC, the value of the current assets and current liabilities shall be based on their audited financial statements prepared in accordance with international financial reporting standards.

If the prospective bidder opts to submit a committed Line of Credit, it must be at least equal to ten percent (10%) of the ABC to be bid. If issued by a foreign universal or commercial bank, it shall be confirmed or authenticated by a local universal or commercial bank.

6. Bidder’s Responsibilities

- 6.1. The Bidder or its duly authorized representative shall submit a sworn statement in the form prescribed in Section VIII. Bidding Forms as required in **ITB** Clause 12.1(b)(iii).
- 6.2. The Bidder is responsible for the following:
 - (a) Having taken steps to carefully examine all of the Bidding Documents;
 - (b) Having acknowledged all conditions, local or otherwise, affecting the implementation of the contract;

- (c) Having made an estimate of the facilities available and needed for the contract to be bid, if any;
- (d) Having complied with its responsibility to inquire or secure Supplemental/Bid Bulletin(s) as provided under **ITB** Clause 10.4.
- (e) Ensuring that it is not “blacklisted” or barred from bidding by the GOP or any of its agencies, offices, corporations, or LGUs, including foreign government/foreign or international financing institution whose blacklisting rules have been recognized by the GPPB;
- (f) Ensuring that each of the documents submitted in satisfaction of the bidding requirements is an authentic copy of the original, complete, and all statements and information provided therein are true and correct;
- (g) Authorizing the HoPE or its duly authorized representative/s to verify all the documents submitted;
- (h) Ensuring that the signatory is the duly authorized representative of the Bidder, and granted full power and authority to do, execute and perform any and all acts necessary and/or to represent the Bidder in the bidding, with the duly notarized Secretary’s Certificate attesting to such fact, if the Bidder is a corporation, partnership, cooperative, or joint venture;
- (i) Complying with the disclosure provision under Section 47 of RA 9184 and its IRR in relation to other provisions of RA 3019;
- (j) Complying with existing labor laws and standards, in the case of procurement of services; Moreover, bidder undertakes to:
 - (i) Ensure the entitlement of workers to wages, hours of work, safety and health and other prevailing conditions of work as established by national laws, rules and regulations; or collective bargaining agreement; or arbitration award, if and when applicable.

In case there is a finding by the Procuring Entity or the DOLE of underpayment or non-payment of workers’ wage and wage-related benefits, bidder agrees that the performance security or portion of the contract amount shall be withheld in favor of the complaining workers pursuant to appropriate provisions of Republic Act No. 9184 without prejudice to the institution of appropriate actions under the Labor Code, as amended, and other social legislations.

- (ii) Comply with occupational safety and health standards and to correct deficiencies, if any.

In case of imminent danger, injury or death of the worker, bidder undertakes to suspend contract implementation pending clearance to proceed from the DOLE Regional Office and to comply with Work Stoppage Order; and

(iii) Inform the workers of their conditions of work, labor clauses under the contract specifying wages, hours of work and other benefits under prevailing national laws, rules and regulations; or collective bargaining agreement; or arbitration award, if and when applicable, through posting in two (2) conspicuous places in the establishment's premises; and

(k) Ensuring that it did not give or pay, directly or indirectly, any commission, amount, fee, or any form of consideration, pecuniary or otherwise, to any person or official, personnel or representative of the government in relation to any procurement project or activity.

Failure to observe any of the above responsibilities shall be at the risk of the Bidder concerned.

- 6.3. The Bidder is expected to examine all instructions, forms, terms, and specifications in the Bidding Documents.
- 6.4. It shall be the sole responsibility of the Bidder to determine and to satisfy itself by such means as it considers necessary or desirable as to all matters pertaining to the contract to be bid, including: (a) the location and the nature of this Project; (b) climatic conditions; (c) transportation facilities; and (d) other factors that may affect the cost, duration, and execution or implementation of this Project.
- 6.5. The Procuring Entity shall not assume any responsibility regarding erroneous interpretations or conclusions by the prospective or eligible bidder out of the data furnished by the procuring entity. However, the Procuring Entity shall ensure that all information in the Bidding Documents, including bid/supplemental bid bulletin/s issued, are correct and consistent.
- 6.6. Before submitting their bids, the Bidder is deemed to have become familiar with all existing laws, decrees, ordinances, acts and regulations of the Philippines which may affect this Project in any way.
- 6.7. The Bidder shall bear all costs associated with the preparation and submission of his bid, and the Procuring Entity will in no case be responsible or liable for those costs, regardless of the conduct or outcome of the bidding process.
- 6.8. The Bidder should note that the Procuring Entity will accept bids only from those that have paid the applicable fee for the Bidding Documents at the office indicated in the Invitation to Bid.

7. Origin of Goods

Unless otherwise indicated in the **BDS**, there is no restriction on the origin of goods other than those prohibited by a decision of the United Nations Security Council taken under Chapter VII of the Charter of the United Nations, subject to **ITB** Clause 27.1.

8. Subcontracts

- 8.1. Unless otherwise specified in the **BDS**, the Bidder may subcontract portions of the Goods to an extent as may be approved by the Procuring Entity and stated in the **BDS**. However, subcontracting of any portion shall not relieve the Bidder from any liability or obligation that may arise from the contract for this Project.
- 8.2. Subcontractors must submit the documentary requirements under **ITB** Clause 12 and comply with the eligibility criteria specified in the **BDS**. In the event that any subcontractor is found by the Procuring Entity to be ineligible, the subcontracting of such portion of the Goods shall be disallowed.
- 8.3. The Bidder may identify the subcontractor to whom a portion of the Goods will be subcontracted at any stage of the bidding process or during contract implementation. If the Bidder opts to disclose the name of the subcontractor during bid submission, the Bidder shall include the required documents as part of the technical component of its bid.

B. Contents of Bidding Documents

9. Pre-Bid Conference

- 9.1. (a) If so specified in the **BDS**, a pre-bid conference shall be held at the venue and on the date indicated therein, to clarify and address the Bidders' questions on the technical and financial components of this Project.

(b) The pre-bid conference shall be held at least twelve (12) calendar days before the deadline for the submission and receipt of bids, but not earlier than seven (7) calendar days from the posting of the invitation to bid. If the Procuring Entity determines that, by reason of the method, nature, or complexity of the contract to be bid, or when international participation will be more advantageous to the GOP, a longer period for the preparation of bids is necessary, the pre-bid conference shall be held at least thirty (30) calendar days before the deadline for the submission and receipt of bids, as specified in the **BDS**.
- 9.2. Bidders are encouraged to attend the pre-bid conference to ensure that they fully understand the Procuring Entity's requirements. Non-attendance of the Bidder will in no way prejudice its bid; however, the Bidder is expected to know the changes and/or amendments to the Bidding Documents as recorded in the minutes of the pre-bid conference and the Supplemental/Bid Bulletin. The minutes of the pre-bid conference shall be recorded and prepared not later than five (5) calendar days after

the pre-bid conference. The minutes shall be made available to prospective bidders not later than five (5) days upon written request.

- 9.3 Decisions of the BAC amending any provision of the bidding documents shall be issued in writing through a Supplemental/Bid Bulletin at least seven (7) calendar days before the deadline for the submission and receipt of bids.

10. Clarification and Amendment of Bidding Documents

- 10.1. Prospective bidders may request for clarification on and/or interpretation of any part of the Bidding Documents. Such request must be in writing and submitted to the Procuring Entity at the address indicated in the **BDS** at least ten (10) calendar days before the deadline set for the submission and receipt of Bids.
- 10.2. The BAC shall respond to the said request by issuing a Supplemental/Bid Bulletin, to be made available to all those who have properly secured the Bidding Documents, at least seven (7) calendar days before the deadline for the submission and receipt of Bids.
- 10.3. Supplemental/Bid Bulletins may also be issued upon the Procuring Entity's initiative for purposes of clarifying or modifying any provision of the Bidding Documents not later than seven (7) calendar days before the deadline for the submission and receipt of Bids. Any modification to the Bidding Documents shall be identified as an amendment.
- 10.4. Any Supplemental/Bid Bulletin issued by the BAC shall also be posted in the website of the Procuring Entity concerned and at any conspicuous place in the premises of the Procuring Entity concerned. It shall be the responsibility of all Bidders who have properly secured the Bidding Documents to inquire and secure Supplemental/Bid Bulletins that may be issued by the BAC. However, Bidders who have submitted bids before the issuance of the Supplemental/Bid Bulletin must be informed and allowed to modify or withdraw their bids in accordance with **ITB** Clause 23.

C. Preparation of Bids

11. Language of Bids

The eligibility requirements or statements, the bids, and all other documents to be submitted to the BAC must be in English. If the eligibility requirements or statements, the bids, and all other documents submitted to the BAC are in foreign language other than English, it must be accompanied by a translation of the documents in English. The documents shall be translated by the relevant foreign government agency, the foreign government agency authorized to translate documents, or a registered translator in the foreign bidder's country; and shall be authenticated by the appropriate Philippine foreign service establishment/post or the equivalent office having jurisdiction over the foreign

bidder's affairs in the Philippines. The English translation shall govern, for purposes of interpretation of the bid.

12. Documents Comprising the Bid: Eligibility and Technical Components

12.1. Unless otherwise indicated in the **BDS**, the first envelope shall contain the following eligibility and technical documents:

(a) Eligibility Documents –

Class “A” Documents:

- (i) PhilGEPS Certificate of Registration and Membership in accordance with Section 8.5.2 of the IRR, except for foreign bidders participating in the procurement by a Philippine Foreign Service Office or Post, which shall submit their eligibility documents under Section 23.1 of the IRR, provided, that the winning bidder shall register with the PhilGEPS in accordance with section 37.1.4 of the **IRR**.
- (ii) Statement of all its on-going government and private contracts, including contracts awarded but not yet started, if any, whether similar or not similar in nature and complexity to the contract to be bid; and

Statement of the Bidder's SLCC similar to the contract to be bid, in accordance with ITB Clause 5.4, within the relevant period as provided in the **BDS**.

The two statements required shall indicate for each contract the following:

- (ii.1) name of the contract;
- (ii.2) date of the contract;
- (ii.3) contract duration;
- (ii.4) owner's name and address;
- (ii.5) kinds of Goods;
- (ii.6) For Statement of On-going Contracts - amount of contract and value of outstanding contracts;
- (ii.7) For Statement of SLCC - amount of completed contracts, adjusted by the Bidder to current prices using PSA's

consumer price index, if necessary for the purpose of meeting the SLCC requirement;

(ii.8) date of delivery; and

(ii.9) end user's acceptance or official receipt(s) or sales invoice issued for the contract, if completed, which shall be attached to the statements.

(iii) NFCC computation in accordance with ITB Clause 5.5 or a committed Line of Credit from a universal or commercial bank.

Class "B" Document:

(iv) If applicable, the Joint Venture Agreement (JVA) in case the joint venture is already in existence, or duly notarized statements from all the potential joint venture partners in accordance with Section 23.1(b) of the IRR.

(b) Technical Documents –

(i) Bid security in accordance with **ITB** Clause 18. If the Bidder opts to submit the bid security in the form of:

(i.1) a bank draft/guarantee or an irrevocable letter of credit issued by a foreign bank, it shall be accompanied by a confirmation from a Universal or Commercial Bank; or

(i.2) a surety bond, it shall be accompanied by a certification by the Insurance Commission that the surety or insurance company is authorized to issue such instruments;

(ii) Conformity with technical specifications, as enumerated and specified in Sections VI and VII of the Bidding Documents; and

(iii) Sworn statement in accordance with Section 25.3 of the IRR of RA 9184 and using the form prescribed in Section VIII. Bidding Forms. Include that, ***"It is authorizing the BAC, HoPE or his duly authorized representative/s to open and verify the submitted eligibility requirements and bid proposal without their actual presence at the venue and via Zoom Meeting"***

(iv) For foreign bidders claiming eligibility by reason of their country's extension of reciprocal rights to Filipinos, a certification from the relevant government office of their country stating that Filipinos are allowed to participate in their government procurement activities for the same item or product.

13. Documents Comprising the Bid: Financial Component

- 13.1. Unless otherwise stated in the **BDS**, the financial component of the bid shall contain the following:
- (a) Financial Bid Form, which includes bid prices and the applicable Price Schedules, in accordance with **ITB** Clauses 15.1 and 15.4;
 - (b) If the Bidder claims preference as a Domestic Bidder, a certification from the DTI issued in accordance with **ITB** Clause 27, unless otherwise provided in the **BDS**; and
 - (c) Any other document related to the financial component of the bid as stated in the **BDS**.
- 13.2.
- (a) Unless otherwise stated in the **BDS**, all bids that exceed the ABC shall not be accepted.
 - (b) Unless otherwise indicated in the **BDS**, for foreign-funded procurement, a ceiling may be applied to bid prices provided the following conditions are met:
 - (i) Bidding Documents are obtainable free of charge on a freely accessible website. If payment of Bidding Documents is required by the procuring entity, payment could be made upon the submission of bids.
 - (ii) The procuring entity has procedures in place to ensure that the ABC is based on recent estimates made by the responsible unit of the procuring entity and that the estimates reflect the quality, supervision and risk and inflationary factors, as well as prevailing market prices, associated with the types of works or goods to be procured.
 - (iii) The procuring entity has trained cost estimators on estimating prices and analyzing bid variances.
 - (iv) The procuring entity has established a system to monitor and report bid prices relative to ABC and engineer's/procuring entity's estimate.
 - (v) The procuring entity has established a monitoring and evaluation system for contract implementation to provide a feedback on actual total costs of goods and works.

14. Alternative Bids

- 14.1 Alternative Bids shall be rejected. For this purpose, alternative bid is an offer made by a Bidder in addition or as a substitute to its original bid which may be included as part of its original bid or submitted separately therewith for purposes of bidding. A bid with options is considered an alternative bid regardless of whether said bid

proposal is contained in a single envelope or submitted in two (2) or more separate bid envelopes.

- 14.2 Each Bidder shall submit only one Bid, either individually or as a partner in a JV. A Bidder who submits or participates in more than one bid (other than as a subcontractor if a subcontractor is permitted to participate in more than one bid) will cause all the proposals with the Bidder's participation to be disqualified. This shall be without prejudice to any applicable criminal, civil and administrative penalties that may be imposed upon the persons and entities concerned.

15. Bid Prices

- 15.1. The Bidder shall complete the appropriate Schedule of Prices included herein, stating the unit prices, total price per item, the total amount and the expected countries of origin of the Goods to be supplied under this Project.
- 15.2. The Bidder shall fill in rates and prices for all items of the Goods described in the Schedule of Prices. Bids not addressing or providing all of the required items in the Bidding Documents including, where applicable, Schedule of Prices, shall be considered non-responsive and, thus, automatically disqualified. In this regard, where a required item is provided, but no price is indicated, the same shall be considered as non-responsive, but specifying a zero (0) or a dash (-) for the said item would mean that it is being offered for free to the procuring entity, except those required by law or regulations to be accomplished.
- 15.3. The terms Ex Works (EXW), Cost, Insurance and Freight (CIF), Cost and Insurance Paid to (CIP), Delivered Duty Paid (DDP), and other trade terms used to describe the obligations of the parties, shall be governed by the rules prescribed in the current edition of the International Commercial Terms (INCOTERMS) published by the International Chamber of Commerce, Paris.
- 15.4. Prices indicated on the Price Schedule shall be entered separately in the following manner:
- (a) For Goods offered from within the Procuring Entity's country:
 - (i) The price of the Goods quoted EXW (ex works, ex factory, ex warehouse, ex showroom, or off-the-shelf, as applicable);
 - (ii) The cost of all customs duties and sales and other taxes already paid or payable;
 - (iii) The cost of transportation, insurance, and other costs incidental to delivery of the Goods to their final destination; and
 - (iv) The price of other (incidental) services, if any, listed in the **BDS**.
 - (b) For Goods offered from abroad:

- (i) Unless otherwise stated in the **BDS**, the price of the Goods shall be quoted DDP with the place of destination in the Philippines as specified in the **BDS**. In quoting the price, the Bidder shall be free to use transportation through carriers registered in any eligible country. Similarly, the Bidder may obtain insurance services from any eligible source country.
 - (ii) The price of other (incidental) services, if any, listed in the **BDS**.
 - (c) For Services, based on the form which may be prescribed by the Procuring Entity, in accordance with existing laws, rules and regulations
- 15.5. Prices quoted by the Bidder shall be fixed during the Bidder's performance of the contract and not subject to variation or price escalation on any account. A bid submitted with an adjustable price quotation shall be treated as non-responsive and shall be rejected, pursuant to **ITB** Clause 24.

All bid prices for the given scope of work in the contract as awarded shall be considered as fixed prices, and therefore not subject to price escalation during contract implementation, except under extraordinary circumstances. Upon the recommendation of the Procuring Entity, price escalation may be allowed in extraordinary circumstances as may be determined by the National Economic and Development Authority in accordance with the Civil Code of the Philippines, and upon approval by the GPPB. Nevertheless, in cases where the cost of the awarded contract is affected by any applicable new laws, ordinances, regulations, or other acts of the GOP, promulgated after the date of bid opening, a contract price adjustment shall be made or appropriate relief shall be applied on a no loss-no gain basis.

16. Bid Currencies

- 16.1. Prices shall be quoted in the following currencies:
- (a) For Goods that the Bidder will supply from within the Philippines, the prices shall be quoted in Philippine Pesos.
 - (b) For Goods that the Bidder will supply from outside the Philippines, the prices may be quoted in the currency(ies) stated in the **BDS**. However, for purposes of bid evaluation, bids denominated in foreign currencies shall be converted to Philippine currency based on the exchange rate as published in the *Bangko Sentral ng Pilipinas* (BSP) reference rate bulletin on the day of the bid opening.
- 16.2. If so allowed in accordance with **ITB** Clause 16.1, the Procuring Entity for purposes of bid evaluation and comparing the bid prices will convert the amounts in various currencies in which the bid price is expressed to Philippine Pesos at the foregoing exchange rates.

- 16.3. Unless otherwise specified in the **BDS**, payment of the contract price shall be made in Philippine Pesos.

17. Bid Validity

- 17.1. Bids shall remain valid for the period specified in the **BDS** which shall not exceed one hundred twenty (120) calendar days from the date of the opening of bids.
- 17.2. In exceptional circumstances, prior to the expiration of the bid validity period, the Procuring Entity may request Bidders to extend the period of validity of their bids. The request and the responses shall be made in writing. The bid security described in **ITB** Clause 18 should also be extended corresponding to the extension of the bid validity period at the least. A Bidder may refuse the request without forfeiting its bid security, but his bid shall no longer be considered for further evaluation and award. A Bidder granting the request shall not be required or permitted to modify its bid.

18. Bid Security

- 18.1. The Bidder shall submit a Bid Securing Declaration or any form of Bid Security in the amount stated in the **BDS**, which shall be not less than the percentage of the ABC in accordance with the following schedule:

Form of Bid Security	Amount of Bid Security (Not Less than the Percentage of the ABC)
(a) Cash or cashier's/manager's check issued by a Universal or Commercial Bank.	Two percent (2%)
(b) Bank draft/guarantee or irrevocable letter of credit issued by a Universal or Commercial Bank: Provided, however, that it shall be confirmed or authenticated by a Universal or Commercial Bank, if issued by a foreign bank.	

The Bid Securing Declaration mentioned above is an undertaking which states, among others, that the Bidder shall enter into contract with the procuring entity and furnish the performance security required under **ITB** Clause 33.2, within ten (10) calendar days from receipt of the Notice of Award, and commits to pay the corresponding amount as fine, and be suspended for a period of time from being qualified to participate in any government procurement activity in the event it

violates any of the conditions stated therein as provided in the guidelines issued by the GPPB.

- 18.2. The bid security should be valid for the period specified in the **BDS**. Any bid not accompanied by an acceptable bid security shall be rejected by the Procuring Entity as non-responsive.
- 18.3. No bid securities shall be returned to Bidders after the opening of bids and before contract signing, except to those that failed or declared as post-disqualified, upon submission of a written waiver of their right to file a request for reconsideration and/or protest, or upon the lapse of the reglementary period to file a request for reconsideration or protest. Without prejudice on its forfeiture, bid securities shall be returned only after the Bidder with the Lowest Calculated Responsive Bid (LCRB) has signed the contract and furnished the performance security, but in no case later than the expiration of the bid security validity period indicated in **ITB** Clause 18.2.
- 18.4. Upon signing and execution of the contract pursuant to **ITB** Clause 32, and the posting of the performance security pursuant to **ITB** Clause 33, the successful Bidder's bid security will be discharged, but in no case later than the bid security validity period as indicated in the **ITB** Clause 18.2.
- 18.5. The bid security may be forfeited:
 - (a) if a Bidder:
 - (i) withdraws its bid during the period of bid validity specified in **ITB** Clause 17;
 - (ii) does not accept the correction of errors pursuant to **ITB** Clause 28.3(b);
 - (iii) has a finding against the veracity of any of the documents submitted as stated in **ITB** Clause 29.2;
 - (iv) submission of eligibility requirements containing false information or falsified documents;
 - (v) submission of bids that contain false information or falsified documents, or the concealment of such information in the bids in order to influence the outcome of eligibility screening or any other stage of the public bidding;
 - (vi) allowing the use of one's name, or using the name of another for purposes of public bidding;

- (vii) withdrawal of a bid, or refusal to accept an award, or enter into contract with the Government without justifiable cause, after the Bidder had been adjudged as having submitted the LCRB;
 - (viii) refusal or failure to post the required performance security within the prescribed time;
 - (ix) refusal to clarify or validate in writing its bid during post-qualification within a period of seven (7) calendar days from receipt of the request for clarification;
 - (x) any documented attempt by a Bidder to unduly influence the outcome of the bidding in his favor;
 - (xi) failure of the potential joint venture partners to enter into the joint venture after the bid is declared successful; or
 - (xii) all other acts that tend to defeat the purpose of the competitive bidding, such as habitually withdrawing from bidding, submitting late Bids or patently insufficient bid, for at least three (3) times within a year, except for valid reasons.
- (b) if the successful Bidder:
- (i) fails to sign the contract in accordance with **ITB** Clause 32; or
 - (ii) fails to furnish performance security in accordance with **ITB** Clause 33.

19. Format and Signing of Bids

- 19.1. Bidders shall submit their bids through their duly authorized representative using the appropriate forms provided in Section VIII. Bidding Forms on or before the deadline specified in the **ITB** Clauses 21 in two (2) separate sealed bid envelopes and which shall be submitted simultaneously. The first shall contain the technical component of the bid, including the eligibility requirements under **ITB** Clause 12.1, and the second shall contain the financial component of the bid. This shall also be observed for each lot in the case of lot procurement.
- 19.2. Forms as mentioned in **ITB** Clause 19.1 must be completed without any alterations to their format, and no substitute form shall be accepted. All blank spaces shall be filled in with the information requested.
- 19.3. The Bidder shall prepare and submit an original of the first and second envelopes as described in **ITB** Clauses 12 and 13. In addition, the Bidder shall submit copies of the first and second envelopes. In the event of any discrepancy between the original and the copies, the original shall prevail.

- 19.4. Each and every page of the Bid Form, including the Schedule of Prices, under Section VIII hereof, shall be signed by the duly authorized representative/s of the Bidder. Failure to do so shall be a ground for the rejection of the bid.
- 19.5. Any interlineations, erasures, or overwriting shall be valid only if they are signed or initialled by the duly authorized representative/s of the Bidder.

20. Sealing and Marking of Bids

- 20.1. Bidders shall enclose their original eligibility and technical documents described in **ITB** Clause 12 in one sealed envelope marked “ORIGINAL - TECHNICAL COMPONENT”, and the original of their financial component in another sealed envelope marked “ORIGINAL - FINANCIAL COMPONENT”, sealing them all in an outer envelope marked “ORIGINAL BID”.
- 20.2. Each copy of the first and second envelopes shall be similarly sealed duly marking the inner envelopes as “COPY NO. ___ - TECHNICAL COMPONENT” and “COPY NO. ___ – FINANCIAL COMPONENT” and the outer envelope as “COPY NO. ___”, respectively. These envelopes containing the original and the copies shall then be enclosed in one single envelope.
- 20.3. The original and the number of copies of the Bid as indicated in the **BDS** shall be typed or written in ink and shall be signed by the Bidder or its duly authorized representative/s.
- 20.4. All envelopes shall:
 - (a) contain the name of the contract to be bid in capital letters;
 - (b) bear the name and address of the Bidder in capital letters;
 - (c) be addressed to the Procuring Entity’s BAC in accordance with **ITB** Clause 1.1;
 - (d) bear the specific identification of this bidding process indicated in the **ITB** Clause 1.1; and
 - (e) bear a warning “DO NOT OPEN BEFORE...” the date and time for the opening of bids, in accordance with **ITB** Clause 21.
- 20.5. Bid envelopes that are not properly sealed and marked, as required in the bidding documents, shall not be rejected, but the Bidder or its duly authorized representative shall acknowledge such condition of the bid as submitted. The BAC or the Procuring Entity shall assume no responsibility for the misplacement of the contents of the improperly sealed or marked bid, or for its premature opening.

D. Submission and Opening of Bids

21. Deadline for Submission of Bids

Bids must be received by the Procuring Entity's BAC at the address and on or before the date and time indicated in the **BDS**.

22. Late Bids

Any bid submitted after the deadline for submission and receipt of bids prescribed by the Procuring Entity, pursuant to **ITB** Clause 21, shall be declared "Late" and shall not be accepted by the Procuring Entity. The BAC shall record in the minutes of bid submission and opening, the Bidder's name, its representative and the time the late bid was submitted.

23. Modification and Withdrawal of Bids

23.1. The Bidder may modify its bid after it has been submitted; provided that the modification is received by the Procuring Entity prior to the deadline prescribed for submission and receipt of bids. The Bidder shall not be allowed to retrieve its original bid, but shall be allowed to submit another bid equally sealed and properly identified in accordance with **ITB** Clause 20, linked to its original bid marked as "TECHNICAL MODIFICATION" or "FINANCIAL MODIFICATION" and stamped "received" by the BAC. Bid modifications received after the applicable deadline shall not be considered and shall be returned to the Bidder unopened.

23.2. A Bidder may, through a Letter of Withdrawal, withdraw its bid after it has been submitted, for valid and justifiable reason; provided that the Letter of Withdrawal is received by the Procuring Entity prior to the deadline prescribed for submission and receipt of bids. The Letter of Withdrawal must be executed by the duly authorized representative of the Bidder identified in the Omnibus Sworn Statement, a copy of which should be attached to the letter.

23.3. Bids requested to be withdrawn in accordance with **ITB** Clause 23.1 shall be returned unopened to the Bidders. A Bidder, who has acquired the bidding documents, may also express its intention not to participate in the bidding through a letter which should reach and be stamped by the BAC before the deadline for submission and receipt of bids. A Bidder that withdraws its bid shall not be permitted to submit another bid, directly or indirectly, for the same contract.

23.4. No bid may be modified after the deadline for submission of bids. No bid may be withdrawn in the interval between the deadline for submission of bids and the expiration of the period of bid validity specified by the Bidder on the Financial Bid Form. Withdrawal of a bid during this interval shall result in the forfeiture of the Bidder's bid security, pursuant to **ITB** Clause 18.5, and the imposition of administrative, civil and criminal sanctions as prescribed by RA 9184 and its IRR.

24. Opening and Preliminary Examination of Bids

- 24.1. The BAC shall open the bids in public, immediately after the deadline for the submission and receipt of bids, as specified in the **BDS**. In case the Bids cannot be opened as scheduled due to justifiable reasons, the BAC shall take custody of the Bids submitted and reschedule the opening of Bids on the next working day or at the soonest possible time through the issuance of a Notice of Postponement to be posted in the website of the Procuring Entity concerned.
- 24.2. Unless otherwise specified in the **BDS**, the BAC shall open the first bid envelopes and determine each Bidder's compliance with the documents prescribed in **ITB** Clause 12, using a non-discretionary "pass/fail" criterion. If a Bidder submits the required document, it shall be rated "passed" for that particular requirement. In this regard, bids that fail to include any requirement or are incomplete or patently insufficient shall be considered as "failed". Otherwise, the BAC shall rate the said first bid envelope as "passed".
- 24.3. Unless otherwise specified in the **BDS**, immediately after determining compliance with the requirements in the first envelope, the BAC shall forthwith open the second bid envelope of each remaining eligible bidder whose first bid envelope was rated "passed". The second envelope of each complying bidder shall be opened within the same day. In case one or more of the requirements in the second envelope of a particular bid is missing, incomplete or patently insufficient, and/or if the submitted total bid price exceeds the ABC unless otherwise provided in **ITB** Clause 13.2, the BAC shall rate the bid concerned as "failed". Only bids that are determined to contain all the bid requirements for both components shall be rated "passed" and shall immediately be considered for evaluation and comparison.
- 24.4. Letters of Withdrawal shall be read out and recorded during bid opening, and the envelope containing the corresponding withdrawn bid shall be returned to the Bidder unopened.
- 24.5. All members of the BAC who are present during bid opening shall initial every page of the original copies of all bids received and opened.
- 24.6. In the case of an eligible foreign bidder as described in **ITB** Clause 5, the following Class "A" Documents may be substituted with the appropriate equivalent documents, if any, issued by the country of the foreign Bidder concerned, which shall likewise be uploaded and maintained in the PhilGEPS in accordance with Section 8.5.2 of the IRR:
 - (a) Registration certificate from the Securities and Exchange Commission (SEC), Department of Trade and Industry (DTI) for sole proprietorship, or CDA for cooperatives;
 - (b) Mayor's/Business permit issued by the local government where the principal place of business of the bidder is located; and

- (c) Audited Financial Statements showing, among others, the prospective bidder's total and current assets and liabilities stamped "received" by the Bureau of Internal Revenue or its duly accredited and authorized institutions, for the preceding calendar year which should not be earlier than two years from the date of bid submission.
- 24.7. Each partner of a joint venture agreement shall likewise submit the requirements in **ITB** Clause 12.1(a)(i). Submission of documents required under **ITB** Clauses 12.1(a)(ii) to 12.1(a)(iii) by any of the joint venture partners constitutes compliance.
- 24.8. The Procuring Entity shall prepare the minutes of the proceedings of the bid opening that shall include, as a minimum: (a) names of Bidders, their bid price (per lot, if applicable, and/or including discount, if any), bid security, findings of preliminary examination, and whether there is a withdrawal or modification; and (b) attendance sheet. The BAC members shall sign the abstract of bids as read.
- 24.8. The bidders or their duly authorized representatives may attend the opening of bids. The BAC shall ensure the integrity, security, and confidentiality of all submitted bids. The Abstract of Bids as read and the minutes of the bid opening shall be made available to the public upon written request and payment of a specified fee to recover cost of materials.
- 24.9. To ensure transparency and accurate representation of the bid submission, the BAC Secretariat shall notify in writing all bidders whose bids it has received through its PhilGEPS-registered physical address or official e-mail address. The notice shall be issued within seven (7) calendar days from the date of the bid opening.

E. Evaluation and Comparison of Bids

25. Process to be Confidential

- 25.1. Members of the BAC, including its staff and personnel, as well as its Secretariat and TWG, are prohibited from making or accepting any kind of communication with any bidder regarding the evaluation of their bids until the issuance of the Notice of Award, unless otherwise allowed in the case of **ITB** Clause 26.
- 25.2. Any effort by a bidder to influence the Procuring Entity in the Procuring Entity's decision in respect of bid evaluation, bid comparison or contract award will result in the rejection of the Bidder's bid.

26. Clarification of Bids

To assist in the evaluation, comparison, and post-qualification of the bids, the Procuring Entity may ask in writing any Bidder for a clarification of its bid. All responses to requests for clarification shall be in writing. Any clarification submitted by a Bidder in respect to its bid and that is not in response to a request by the Procuring Entity shall not be considered.

27. Domestic Preference

- 27.1. Unless otherwise stated in the **BDS**, the Procuring Entity will grant a margin of preference for the purpose of comparison of bids in accordance with the following:
- (a) The preference shall be applied when the lowest Foreign Bid is lower than the lowest bid offered by a Domestic Bidder.
 - (b) For evaluation purposes, the lowest Foreign Bid shall be increased by fifteen percent (15%).
 - (c) In the event that the lowest bid offered by a Domestic Bidder does not exceed the lowest Foreign Bid as increased, then the Procuring Entity shall award the contract to the Domestic Bidder at the amount of the lowest Foreign Bid.
 - (d) If the Domestic Bidder refuses to accept the award of contract at the amount of the Foreign Bid within two (2) calendar days from receipt of written advice from the BAC, the Procuring Entity shall award to the bidder offering the Foreign Bid, subject to post-qualification and submission of all the documentary requirements under these Bidding Documents.
- 27.2. A Bidder may be granted preference as a Domestic Bidder subject to the certification from the DTI that the Bidder is offering unmanufactured articles, materials or supplies of the growth or production of the Philippines, or manufactured articles, materials, or supplies manufactured or to be manufactured in the Philippines substantially from articles, materials, or supplies of the growth, production, or manufacture, as the case may be, of the Philippines.

28. Detailed Evaluation and Comparison of Bids

- 28.1. The Procuring Entity will undertake the detailed evaluation and comparison of bids which have passed the opening and preliminary examination of bids, pursuant to **ITB** Clause 24, in order to determine the Lowest Calculated Bid.
- 28.2. The Lowest Calculated Bid shall be determined in two steps:
- (a) The detailed evaluation of the financial component of the bids, to establish the correct calculated prices of the bids; and
 - (b) The ranking of the total bid prices as so calculated from the lowest to the highest. The bid with the lowest price shall be identified as the Lowest Calculated Bid.
- 28.3. The Procuring Entity's BAC shall immediately conduct a detailed evaluation of all bids rated "passed," using non-discretionary pass/fail criteria. The BAC shall consider the following in the evaluation of bids:

- (a) Completeness of the bid. Unless the **BDS** allows partial bids, bids not addressing or providing all of the required items in the Schedule of Requirements including, where applicable, Schedule of Prices, shall be considered non-responsive and, thus, automatically disqualified. In this regard, where a required item is provided, but no price is indicated, the same shall be considered as non-responsive, but specifying a zero (0) or a dash (-) for the said item would mean that it is being offered for free to the Procuring Entity, except those required by law or regulations to be provided for; and
 - (b) Arithmetical corrections. Consider computational errors and omissions to enable proper comparison of all eligible bids. It may also consider bid modifications. Any adjustment shall be calculated in monetary terms to determine the calculated prices.
- 28.4. Based on the detailed evaluation of bids, those that comply with the above-mentioned requirements shall be ranked in the ascending order of their total calculated bid prices, as evaluated and corrected for computational errors, discounts and other modifications, to identify the Lowest Calculated Bid. Total calculated bid prices, as evaluated and corrected for computational errors, discounts and other modifications, which exceed the ABC shall not be considered, unless otherwise indicated in the **BDS**.
- 28.5. The Procuring Entity's evaluation of bids shall be based on the bid price quoted in the Bid Form, which includes the Schedule of Prices.
- 28.6. Bids shall be evaluated on an equal footing to ensure fair competition. For this purpose, all bidders shall be required to include in their bids the cost of all taxes, such as, but not limited to, value added tax (VAT), income tax, local taxes, and other fiscal levies and duties which shall be itemized in the bid form and reflected in the detailed estimates. Such bids, including said taxes, shall be the basis for bid evaluation and comparison.
- 28.7. If so indicated pursuant to **ITB** Clause 1.2, Bids are being invited for individual lots or for any combination thereof, provided that all Bids and combinations of Bids shall be received by the same deadline and opened and evaluated simultaneously so as to determine the Bid or combination of Bids offering the lowest calculated cost to the Procuring Entity. Bid prices quoted shall correspond to all items specified for each lot and to all quantities specified for each item of a lot. Bid Security as required by **ITB** Clause 18 shall be submitted for each contract (lot) separately. The basis for evaluation of lots is specified in **BDS** Clause 28.3.

29. Post-Qualification

- 29.1. The BAC shall determine to its satisfaction whether the Bidder that is evaluated as having submitted the Lowest Calculated Bid complies with and is responsive to all the requirements and conditions specified in **ITB** Clauses 5, 12, and 13.

- 29.2. Within a non-extendible period of five (5) calendar days from receipt by the bidder of the notice from the BAC that it submitted the Lowest Calculated Bid, the Bidder shall submit its latest income and business tax returns filed and paid through the BIR Electronic Filing and Payment System (eFPS) and other appropriate licenses and permits required by law and stated in the **BDS**.

Failure to submit any of the post-qualification requirements on time, or a finding against the veracity thereof, shall disqualify the bidder for award. Provided in the event that a finding against the veracity of any of the documents submitted is made, it shall cause the forfeiture of the bid security in accordance with Section 69 of the IRR of RA 9184.

- 29.3. The determination shall be based upon an examination of the documentary evidence of the Bidder's qualifications submitted pursuant to **ITB** Clauses 12 and 13, as well as other information as the Procuring Entity deems necessary and appropriate, using a non-discretionary "pass/fail" criterion, which shall be completed within a period of twelve (12) calendar days.
- 29.4. If the BAC determines that the Bidder with the Lowest Calculated Bid passes all the criteria for post-qualification, it shall declare the said bid as the LCRB, and recommend to the HoPE the award of contract to the said Bidder at its submitted price or its calculated bid price, whichever is lower.
- 29.5. A negative determination shall result in rejection of the Bidder's Bid, in which event the Procuring Entity shall proceed to the next Lowest Calculated Bid with a fresh period to make a similar determination of that Bidder's capabilities to perform satisfactorily. If the second Bidder, however, fails the post qualification, the procedure for post qualification shall be repeated for the Bidder with the next Lowest Calculated Bid, and so on until the LCRB is determined for recommendation for contract award.
- 29.6. Within a period not exceeding fifteen (15) calendar days from the determination by the BAC of the LCRB and the recommendation to award the contract, the HoPE or his duly authorized representative shall approve or disapprove the said recommendation.
- 29.7. In the event of disapproval, which shall be based on valid, reasonable, and justifiable grounds as provided for under Section 41 of the IRR of RA 9184, the HoPE shall notify the BAC and the Bidder in writing of such decision and the grounds for it. When applicable, the BAC shall conduct a post-qualification of the Bidder with the next Lowest Calculated Bid. A request for reconsideration may be filed by the bidder with the HoPE in accordance with Section 37.1.3 of the IRR of RA 9184.

30. Reservation Clause

- 30.1. Notwithstanding the eligibility or post-qualification of a Bidder, the Procuring Entity concerned reserves the right to review its qualifications at any stage of the procurement process if it has reasonable grounds to believe that a misrepresentation has been made by the said Bidder, or that there has been a change in the Bidder's capability to undertake the project from the time it submitted its eligibility requirements. Should such review uncover any misrepresentation made in the eligibility and bidding requirements, statements or documents, or any changes in the situation of the Bidder which will affect its capability to undertake the project so that it fails the preset eligibility or bid evaluation criteria, the Procuring Entity shall consider the said Bidder as ineligible and shall disqualify it from submitting a bid or from obtaining an award or contract.
- 30.2. Based on the following grounds, the Procuring Entity reserves the right to reject any and all bids, declare a Failure of Bidding at any time prior to the contract award, or not to award the contract, without thereby incurring any liability, and make no assurance that a contract shall be entered into as a result of the bidding:
- (a) If there is *prima facie* evidence of collusion between appropriate public officers or employees of the Procuring Entity, or between the BAC and any of the Bidders, or if the collusion is between or among the bidders themselves, or between a Bidder and a third party, including any act which restricts, suppresses or nullifies or tends to restrict, suppress or nullify competition;
 - (b) If the Procuring Entity's BAC is found to have failed in following the prescribed bidding procedures; or
 - (c) For any justifiable and reasonable ground where the award of the contract will not redound to the benefit of the GOP as follows:
 - (i) If the physical and economic conditions have significantly changed so as to render the project no longer economically, financially or technically feasible as determined by the HoPE;
 - (ii) If the project is no longer necessary as determined by the HoPE; and
 - (iii) If the source of funds for the project has been withheld or reduced through no fault of the Procuring Entity.
- 30.3. In addition, the Procuring Entity may likewise declare a failure of bidding when:
- (a) No bids are received;
 - (b) All prospective Bidders are declared ineligible;

- (c) All bids fail to comply with all the bid requirements or fail post-qualification; or
- (d) The bidder with the LCRB refuses, without justifiable cause to accept the award of contract, and no award is made in accordance with Section 40 of the IRR of RA 9184.

F. Award of Contract

31. Contract Award

- 31.1. Subject to **ITB** Clause 29, the HoPE or its duly authorized representative shall award the contract to the Bidder whose bid has been determined to be the LCRB.
- 31.2. Prior to the expiration of the period of bid validity, the Procuring Entity shall notify the successful Bidder in writing that its bid has been accepted, through a Notice of Award duly received by the Bidder or its representative personally or sent by registered mail or electronically, receipt of which must be confirmed in writing within two (2) days by the Bidder with the LCRB and submitted personally or sent by registered mail or electronically to the Procuring Entity.
- 31.3. Notwithstanding the issuance of the Notice of Award, award of contract shall be subject to the following conditions:
 - (a) Submission of the following documents within ten (10) calendar days from receipt of the Notice of Award:
 - (i) Valid JVA, if applicable; or
 - (ii) In the case of procurement by a Philippine Foreign Service Office or Post, the PhilGEPS Registration Number of the winning foreign Bidder;
 - (b) Posting of the performance security in accordance with **ITB** Clause 33;
 - (c) Signing of the contract as provided in **ITB** Clause 32; and
 - (d) Approval by higher authority, if required, as provided in Section 37.3 of the IRR of RA 9184.
- 31.4. At the time of contract award, the Procuring Entity shall not increase or decrease the quantity of goods originally specified in Section VI. Schedule of Requirements

32. Signing of the Contract

- 32.1. At the same time as the Procuring Entity notifies the successful Bidder that its bid has been accepted, the Procuring Entity shall send the Contract Form to the Bidder,

which contract has been provided in the Bidding Documents, incorporating therein all agreements between the parties.

- 32.2. Within ten (10) calendar days from receipt of the Notice of Award, the successful Bidder shall post the required performance security, sign and date the contract and return it to the Procuring Entity.
- 32.3. The Procuring Entity shall enter into contract with the successful Bidder within the same ten (10) calendar day period provided that all the documentary requirements are complied with.
- 32.4. The following documents shall form part of the contract:
 - (a) Contract Agreement;
 - (b) Bidding Documents;
 - (c) Winning bidder's bid, including the Technical and Financial Proposals, and all other documents/statements submitted (*e.g.* bidder's response to request for clarifications on the bid), including corrections to the bid, if any, resulting from the Procuring Entity's bid evaluation;
 - (d) Performance Security;
 - (e) Notice of Award of Contract; and
 - (f) Other contract documents that may be required by existing laws and/or specified in the **BDS**.

33. Performance Security

- 33.1. To guarantee the faithful performance by the winning Bidder of its obligations under the contract, it shall post a performance security within a maximum period of ten (10) calendar days from the receipt of the Notice of Award from the Procuring Entity and in no case later than the signing of the contract.
- 33.2. The Performance Security shall be denominated in Philippine Pesos and posted in favor of the Procuring Entity in an amount not less than the percentage of the total contract price in accordance with the following schedule:

Form of Performance Security	Amount of Performance Security (Not less than the Percentage of the Total Contract Price)
(a) Cash or cashier's/manager's check issued by a Universal or Commercial Bank.	Five percent (5%)

<p>(b) Bank draft/guarantee or irrevocable letter of credit issued by a Universal or Commercial Bank: Provided, however, that it shall be confirmed or authenticated by a Universal or Commercial Bank, if issued by a foreign bank.</p>	
--	--

33.3. Failure of the successful Bidder to comply with the above-mentioned requirement shall constitute sufficient ground for the annulment of the award and forfeiture of the bid security, in which event the Procuring Entity shall have a fresh period to initiate and complete the post qualification of the second Lowest Calculated Bid. The procedure shall be repeated until the LCRB is identified and selected for recommendation of contract award. However if no Bidder passed post-qualification, the BAC shall declare the bidding a failure and conduct a re-bidding with re-advertisement, if necessary

34. Notice to Proceed

Within seven (7) calendar days from the date of approval of the contract by the appropriate government approving authority, the Procuring Entity shall issue the Notice to Proceed (NTP) together with a copy or copies of the approved contract to the successful Bidder. All notices called for by the terms of the contract shall be effective only at the time of receipt thereof by the successful Bidder.

35. Protest Mechanism

Decisions of the procuring entity at any stage of the procurement process may be questioned in accordance with Section 55 of the IRR of RA 9184.

Section III. Bid Data Sheet

Bid Data Sheet

ITB Clause	
1.1	<p>The Procuring Entity is CANORECO</p> <p>The name of the Contract is <i>Supply and Delivery of Materials for DPWH Pole Relocation Project within the Coverage Area of CANORECO</i></p> <p>The identification number of the Contract is <i>Invitation To Bid No. 2020-075</i></p>
1.1	The lot(s) and reference is/are:
2	<p>The Funding Source is:</p> <p>The Government of the Philippines (GOP) through <i>DPWH fund</i> in the amount of <i>Thirty-three Million Nine Hundred Twenty-nine Thousand One Hundred Seventy-nine Pesos only (Php33,929,179.00).</i></p>
3.1	No further instructions.
5.1	No further instructions.
5.2	Foreign bidders, except those falling under ITB Clause 5.2(b), may not participate in this Project
5.4	<p><i>For the procurement of Non-expendable Supplies and Services:</i> The Bidder must have completed, within the period specified in the Invitation to Bid and ITB Clause 12.1(a)(ii), a single contract that is similar to this Project, equivalent to at least fifty percent (50%) of the ABC.</p> <p>For this purpose, similar contracts shall refer to delivery of materials included in Invitation To Bid Form No. 2020-037 to other distribution utilities or private company/corporation/contractor.</p>
7	No further instructions
8.1	Subcontracting is not allowed
8.2	Not applicable
9.1	The Procuring Entity will hold a Pre-bid Conference for this Project on <i>October 29, 2020 (Thursday) 2:00 PM</i> at <i>CANORECO Board Room, 3rd Floor, CANORECO Main Office, Jose P. Rizal Street, Barangay I, Daet, Camarines Norte</i> via ZOOM.

10.1	The Procuring Entity's address is: <i>Camarines Norte Electric Cooperative, Inc. (CANORECO)</i> <i>Jose P. Rizal Street, Barangay I, Daet, Camarines Norte</i> <i>Mary Ann A. Moreno – BAC Chairperson</i> <i>(054) 571-3717/571-3796</i> <i>Canoreco_197505@yahoo.com</i>
12.1(a)	No further instructions.
12.1(a)(ii)	The bidder's SLCC similar to the contract to be bid should have been completed within five (5) years prior to the deadline for the submission and receipt of bids.
13.1	No additional requirements.
13.1(b)	No further instructions.
13.1(c)	No additional requirements.
13.2	The ABC is <i>Thirty-three Million Nine Hundred Twenty-nine Thousand One Hundred Seventy-nine Pesos only (Php33,929,179.00)</i> . Any bid with a financial component exceeding this amount shall not be accepted.
15.4(a)(iv)	No incidental services are required.
15.4(b)	No incidental services are required.
16.1(b)	The Bid prices for Goods supplied from outside of the Philippines shall be quoted in Philippine Pesos.
16.3	Not applicable
17.1	Bids will be valid until <i>120 days from the date of bid opening. (09 March 2021)</i>
18.1	The bid security shall be in the form of a Bid Securing Declaration, or any of the following forms and amounts: 1. The amount of not less than <i>Php678,583.58</i> , if bid security is in cash, cashier's/manager's check, bank draft/guarantee or irrevocable letter of credit; or
18.2	The bid security shall be valid until <i>120 days from the date of Bid Opening.</i>

20.3	Each Bidder shall submit <i>one (1) original and one (1) copy</i> of the first and second components of its bid.
21	The deadline for submission of bids is <i>until 1:59 PM on November 09, 2020 (Tuesday) at CANORECO Board Room, 3rd Floor, Jose P. Rizal Street, Barangay I, Daet, Camarines Norte</i>
24.1	Bid Opening is on <i>September 01, 2020 (Monday) 9:00 am at CANORECO Board Room via ZOOM, 3rd Floor, CANORECO Main Office, Jose P. Rizal Street, Barangay I, Daet, Camarines Norte</i>
24.2	No further instructions.
24.3	No further instructions.
27.1	No further instructions.
28.3 (a)	<p>Grouping and Evaluation of Lots –</p> <p>All items to be grouped together to form one complete Lot that will be awarded to one Bidder to form one complete contract.</p> <p>Partial bid is not allowed. The goods are grouped in a single lot and the lot shall not be divided into sub-lots for the purpose of bidding, evaluation, and contract award.</p> <p>In all cases, the NFCC computation, if applicable, must be sufficient for all the lots or contracts to be awarded to the Bidder.</p>
28.4	No further instructions.
29.2	No additional requirement.
32.4(f)	Notice to Proceed and Board Resolution together with other documents stated under ITB 32.4(f)

Section IV. General Conditions of Contract

TABLE OF CONTENTS

1.	DEFINITIONS	45
2.	CORRUPT, FRAUDULENT, COLLUSIVE AND COERCIVE PRACTICES	46
3.	INSPECTION AND AUDIT BY THE FUNDING SOURCE	47
4.	GOVERNING LAW AND LANGUAGE	47
5.	NOTICES	48
6.	SCOPE OF CONTRACT	48
7.	SUBCONTRACTING	48
8.	PROCURING ENTITY’S RESPONSIBILITIES	48
9.	PRICES	49
10.	PAYMENT	49
11.	ADVANCE PAYMENT AND TERMS OF PAYMENT.....	50
12.	TAXES AND DUTIES	50
13.	PERFORMANCE SECURITY	50
14.	USE OF CONTRACT DOCUMENTS AND INFORMATION	51
15.	STANDARDS	51
16.	INSPECTION AND TESTS	52
17.	WARRANTY	52
18.	DELAYS IN THE SUPPLIER’S PERFORMANCE	53
19.	LIQUIDATED DAMAGES	53
20.	SETTLEMENT OF DISPUTES	54
21.	LIABILITY OF THE SUPPLIER	54

22.	FORCE MAJEURE	55
23.	TERMINATION FOR DEFAULT	55
24.	TERMINATION FOR INSOLVENCY	56
25.	TERMINATION FOR CONVENIENCE	56
26.	TERMINATION FOR UNLAWFUL ACTS	57
27.	PROCEDURES FOR TERMINATION OF CONTRACTS	57
28.	ASSIGNMENT OF RIGHTS	58
29.	CONTRACT AMENDMENT	58
30.	APPLICATION	58

1. Definitions

1.1. In this Contract, the following terms shall be interpreted as indicated:

- (a) “The Contract” means the agreement entered into between the Procuring Entity and the Supplier, as recorded in the Contract Form signed by the parties, including all attachments and appendices thereto and all documents incorporated by reference therein.
- (b) “The Contract Price” means the price payable to the Supplier under the Contract for the full and proper performance of its contractual obligations.
- (c) “The Goods” means all of the supplies, equipment, machinery, spare parts, other materials and/or general support services which the Supplier is required to provide to the Procuring Entity under the Contract.
- (d) “The Services” means those services ancillary to the supply of the Goods, such as transportation and insurance, and any other incidental services, such as installation, commissioning, provision of technical assistance, training, and other such obligations of the Supplier covered under the Contract.
- (e) “GCC” mean the General Conditions of Contract contained in this Section.
- (f) “SCC” means the Special Conditions of Contract.
- (g) “The Procuring Entity” means the organization purchasing the Goods, as named in the SCC.
- (h) “The Procuring Entity’s country” is the Philippines.
- (i) “The Supplier” means the individual contractor, manufacturer distributor, or firm supplying/manufacturing the Goods and Services under this Contract and named in the SCC.
- (j) The “Funding Source” means the organization named in the SCC.
- (k) “The Project Site,” where applicable, means the place or places named in the SCC.
- (l) “Day” means calendar day.
- (m) The “Effective Date” of the contract will be the date of signing the contract, however the Supplier shall commence performance of its obligations only upon receipt of the Notice to Proceed and copy of the approved contract.
- (n) “Verified Report” refers to the report submitted by the Implementing Unit to the HoPE setting forth its findings as to the existence of grounds or causes

for termination and explicitly stating its recommendation for the issuance of a Notice to Terminate.

2. Corrupt, Fraudulent, Collusive, and Coercive Practices

2.1. Unless otherwise provided in the **SCC**, the Procuring Entity as well as the bidders, contractors, or suppliers shall observe the highest standard of ethics during the procurement and execution of this Contract. In pursuance of this policy, the Procuring Entity:

- (a) defines, for the purposes of this provision, the terms set forth below as follows:
 - (i) "corrupt practice" means behaviour on the part of officials in the public or private sectors by which they improperly and unlawfully enrich themselves, others, or induce others to do so, by misusing the position in which they are placed, and it includes the offering, giving, receiving, or soliciting of anything of value to influence the action of any such official in the procurement process or in contract execution; entering, on behalf of the Government, into any contract or transaction manifestly and grossly disadvantageous to the same, whether or not the public officer profited or will profit thereby, and similar acts as provided in Republic Act 3019.
 - (ii) "fraudulent practice" means a misrepresentation of facts in order to influence a procurement process or the execution of a contract to the detriment of the Procuring Entity, and includes collusive practices among Bidders (prior to or after bid submission) designed to establish bid prices at artificial, non-competitive levels and to deprive the Procuring Entity of the benefits of free and open competition.
 - (iii) "collusive practices" means a scheme or arrangement between two or more Bidders, with or without the knowledge of the Procuring Entity, designed to establish bid prices at artificial, non-competitive levels.
 - (iv) "coercive practices" means harming or threatening to harm, directly or indirectly, persons, or their property to influence their participation in a procurement process, or affect the execution of a contract;
 - (v) "obstructive practice" is
 - (aa) deliberately destroying, falsifying, altering or concealing of evidence material to an administrative proceedings or investigation or making false statements to investigators in

order to materially impede an administrative proceedings or investigation of the Procuring Entity or any foreign government/foreign or international financing institution into allegations of a corrupt, fraudulent, coercive or collusive practice; and/or threatening, harassing or intimidating any party to prevent it from disclosing its knowledge of matters relevant to the administrative proceedings or investigation or from pursuing such proceedings or investigation; or

(bb) acts intended to materially impede the exercise of the inspection and audit rights of the Procuring Entity or any foreign government/foreign or international financing institution herein.

(b) will reject a proposal for award if it determines that the Bidder recommended for award has engaged in any of the practices mentioned in this Clause for purposes of competing for the contract.

2.2. Further the Funding Source, Borrower or Procuring Entity, as appropriate, will seek to impose the maximum civil, administrative and/or criminal penalties available under the applicable law on individuals and organizations deemed to be involved with any of the practices mentioned in GCC Clause 2.1(a).

3. Inspection and Audit by the Funding Source

The Supplier shall permit the Funding Source to inspect the Supplier's accounts and records relating to the performance of the Supplier and to have them audited by auditors appointed by the Funding Source, if so required by the Funding Source.

4. Governing Law and Language

4.1. This Contract shall be interpreted in accordance with the laws of the Republic of the Philippines.

4.2. This Contract has been executed in the English language, which shall be the binding and controlling language for all matters relating to the meaning or interpretation of this Contract. All correspondence and other documents pertaining to this Contract exchanged by the parties shall be written in English.

5. Notices

- 5.1. Any notice, request, or consent required or permitted to be given or made pursuant to this Contract shall be in writing. Any such notice, request, or consent shall be deemed to have been given or made when received by the concerned party, either in person or through an authorized representative of the Party to whom the communication is addressed, or when sent by registered mail, telex, telegram, or facsimile to such Party at the address specified in the SCC, which shall be effective when delivered and duly received or on the notice's effective date, whichever is later.
- 5.2. A Party may change its address for notice hereunder by giving the other Party notice of such change pursuant to the provisions listed in the SCC for GCC Clause 5.1.

6. Scope of Contract

- 6.1. The Goods and Related Services to be provided shall be as specified in Section VI. Schedule of Requirements
- 6.2. This Contract shall include all such items, although not specifically mentioned, that can be reasonably inferred as being required for its completion as if such items were expressly mentioned herein. Any additional requirements for the completion of this Contract shall be provided in the SCC.

7. Subcontracting

- 7.1. Subcontracting of any portion of the Goods, if allowed in the **BDS**, does not relieve the Supplier of any liability or obligation under this Contract. The Supplier will be responsible for the acts, defaults, and negligence of any subcontractor, its agents, servants or workmen as fully as if these were the Supplier's own acts, defaults, or negligence, or those of its agents, servants or workmen.
- 7.2. If subcontracting is allowed, the Supplier may identify its subcontractor during contract implementation. Subcontractors disclosed and identified during the bidding may be changed during the implementation of this Contract. In either case, subcontractors must submit the documentary requirements under **ITB** Clause 12 and comply with the eligibility criteria specified in the BDS. In the event that any subcontractor is found by the Procuring Entity to be ineligible, the subcontracting of such portion of the Goods shall be disallowed.

8. Procuring Entity's Responsibilities

- 8.1. Whenever the performance of the obligations in this Contract requires that the Supplier obtain permits, approvals, import, and other licenses from local public authorities, the Procuring Entity shall, if so needed by the Supplier, make its best

effort to assist the Supplier in complying with such requirements in a timely and expeditious manner.

- 8.2. The Procuring Entity shall pay all costs involved in the performance of its responsibilities in accordance with **GCC** Clause 6.

9. Prices

- 9.1. For the given scope of work in this Contract as awarded, all bid prices are considered fixed prices, and therefore not subject to price escalation during contract implementation, except under extraordinary circumstances and upon prior approval of the GPPB in accordance with Section 61 of R.A. 9184 and its IRR or except as provided in this Clause.
- 9.2. Prices charged by the Supplier for Goods delivered and/or services performed under this Contract shall not vary from the prices quoted by the Supplier in its bid, with the exception of any change in price resulting from a Change Order issued in accordance with **GCC** Clause 29.

10. Payment

- 10.1. Payments shall be made only upon a certification by the HoPE to the effect that the Goods have been rendered or delivered in accordance with the terms of this Contract and have been duly inspected and accepted. Except with the prior approval of the President no payment shall be made for services not yet rendered or for supplies and materials not yet delivered under this Contract. Ten percent (10%) of the amount of each payment shall be retained by the Procuring Entity to cover the Supplier's warranty obligations under this Contract as described in **GCC** Clause 17.
- 10.2. The Supplier's request(s) for payment shall be made to the Procuring Entity in writing, accompanied by an invoice describing, as appropriate, the Goods delivered and/or Services performed, and by documents submitted pursuant to the **SCC** provision for **GCC** Clause 6.1, and upon fulfilment of other obligations stipulated in this Contract.
- 10.3. Pursuant to **GCC** Clause 10.2, payments shall be made promptly by the Procuring Entity, but in no case later than sixty (60) days after submission of an invoice or claim by the Supplier. Payments shall be in accordance with the schedule stated in the **SCC**.
- 10.4. Unless otherwise provided in the **SCC**, the currency in which payment is made to the Supplier under this Contract shall be in Philippine Pesos.
- 10.5. Unless otherwise provided in the **SCC**, payments using Letter of Credit (LC), in accordance with the Guidelines issued by the GPPB, is allowed. For this purpose,

the amount of provisional sum is indicated in the SCC. All charges for the opening of the LC and/or incidental expenses thereto shall be for the account of the Supplier.

11. Advance Payment and Terms of Payment

- 11.1. Advance payment shall be made only after prior approval of the President, and shall not exceed fifteen percent (15%) of the Contract amount, unless otherwise directed by the President or in cases allowed under Annex “D” of RA 9184.
- 11.2. All progress payments shall first be charged against the advance payment until the latter has been fully exhausted.
- 11.3. For Goods supplied from abroad, unless otherwise indicated in the SCC, the terms of payment shall be as follows:
 - (a) On Contract Signature: Fifteen Percent (15%) of the Contract Price shall be paid within sixty (60) days from signing of the Contract and upon submission of a claim and a bank guarantee for the equivalent amount valid until the Goods are delivered and in the form provided in Section VIII. Bidding Forms.
 - (b) On Delivery: Sixty-five percent (65%) of the Contract Price shall be paid to the Supplier within sixty (60) days after the date of receipt of the Goods and upon submission of the documents (i) through (vi) specified in the SCC provision on Delivery and Documents.
 - (c) On Acceptance: The remaining twenty percent (20%) of the Contract Price shall be paid to the Supplier within sixty (60) days after the date of submission of the acceptance and inspection certificate for the respective delivery issued by the Procuring Entity’s authorized representative. In the event that no inspection or acceptance certificate is issued by the Procuring Entity’s authorized representative within forty five (45) days of the date shown on the delivery receipt, the Supplier shall have the right to claim payment of the remaining twenty percent (20%) subject to the Procuring Entity’s own verification of the reason(s) for the failure to issue documents (vii) and (viii) as described in the SCC provision on Delivery and Documents.

12. Taxes and Duties

The Supplier, whether local or foreign, shall be entirely responsible for all the necessary taxes, stamp duties, license fees, and other such levies imposed for the completion of this Contract.

13. Performance Security

- 13.1. Within ten (10) calendar days from receipt of the Notice of Award from the Procuring Entity but in no case later than the signing of the contract by both parties,

the successful Bidder shall furnish the performance security in any the forms prescribed in the **ITB** Clause 33.2.

- 13.2. The performance security posted in favor of the Procuring Entity shall be forfeited in the event it is established that the winning bidder is in default in any of its obligations under the contract.
- 13.3. The performance security shall remain valid until issuance by the Procuring Entity of the Certificate of Final Acceptance.
- 13.4. The performance security may be released by the Procuring Entity and returned to the Supplier after the issuance of the Certificate of Final Acceptance subject to the following conditions:
 - (a) There are no pending claims against the Supplier or the surety company filed by the Procuring Entity;
 - (b) The Supplier has no pending claims for labor and materials filed against it; and
 - (c) Other terms specified in the **SCC**.
- 13.5. In case of a reduction of the contract value, the Procuring Entity shall allow a proportional reduction in the original performance security, provided that any such reduction is more than ten percent (10%) and that the aggregate of such reductions is not more than fifty percent (50%) of the original performance security.

14. Use of Contract Documents and Information

- 14.1. The Supplier shall not, except for purposes of performing the obligations in this Contract, without the Procuring Entity's prior written consent, disclose this Contract, or any provision thereof, or any specification, plan, drawing, pattern, sample, or information furnished by or on behalf of the Procuring Entity. Any such disclosure shall be made in confidence and shall extend only as far as may be necessary for purposes of such performance.
- 14.2. Any document, other than this Contract itself, enumerated in **GCC** Clause 14.1 shall remain the property of the Procuring Entity and shall be returned (all copies) to the Procuring Entity on completion of the Supplier's performance under this Contract if so required by the Procuring Entity.

15. Standards

The Goods provided under this Contract shall conform to the standards mentioned in the Section VII. Technical Specifications; when no applicable standard is mentioned, to the authoritative standards appropriate to the Goods' country of origin. Such standards shall be the latest issued by the institution concerned.

16. Inspection and Tests

- 16.1. The Procuring Entity or its representative shall have the right to inspect and/or to test the Goods to confirm their conformity to the Contract specifications at no extra cost to the Procuring Entity. The **SCC** and Section VII. Technical Specifications shall specify what inspections and/or tests the Procuring Entity requires and where they are to be conducted. The Procuring Entity shall notify the Supplier in writing, in a timely manner, of the identity of any representatives retained for these purposes.
- 16.2. If applicable, the inspections and tests may be conducted on the premises of the Supplier or its subcontractor(s), at point of delivery, and/or at the goods' final destination. If conducted on the premises of the Supplier or its subcontractor(s), all reasonable facilities and assistance, including access to drawings and production data, shall be furnished to the inspectors at no charge to the Procuring Entity. The Supplier shall provide the Procuring Entity with results of such inspections and tests.
- 16.3. The Procuring Entity or its designated representative shall be entitled to attend the tests and/or inspections referred to in this Clause provided that the Procuring Entity shall bear all of its own costs and expenses incurred in connection with such attendance including, but not limited to, all travelling and board and lodging expenses.
- 16.4. The Procuring Entity may reject any Goods or any part thereof that fail to pass any test and/or inspection or do not conform to the specifications. The Supplier shall either rectify or replace such rejected Goods or parts thereof or make alterations necessary to meet the specifications at no cost to the Procuring Entity, and shall repeat the test and/or inspection, at no cost to the Procuring Entity, upon giving a notice pursuant to **GCC** Clause 5.
- 16.5. The Supplier agrees that neither the execution of a test and/or inspection of the Goods or any part thereof, nor the attendance by the Procuring Entity or its representative, shall release the Supplier from any warranties or other obligations under this Contract.

17. Warranty

- 17.1. The Supplier warrants that the Goods supplied under the Contract are new, unused, of the most recent or current models, and that they incorporate all recent improvements in design and materials, except when the technical specifications required by the Procuring Entity provides otherwise.
- 17.2. The Supplier further warrants that all Goods supplied under this Contract shall have no defect, arising from design, materials, or workmanship or from any act or omission of the Supplier that may develop under normal use of the supplied Goods in the conditions prevailing in the country of final destination.

- 17.3. In order to assure that manufacturing defects shall be corrected by the Supplier, a warranty shall be required from the Supplier for a minimum period specified in the **SCC**. The obligation for the warranty shall be covered by, at the Supplier's option, either retention money in an amount equivalent to at least one percent (1%) of every progress payment, or a special bank guarantee equivalent to at least one percent (1%) of the total Contract Price or other such amount if so specified in the **SCC**. The said amounts shall only be released after the lapse of the warranty period specified in the **SCC**; provided, however, that the Supplies delivered are free from patent and latent defects and all the conditions imposed under this Contract have been fully met.
- 17.4. The Procuring Entity shall promptly notify the Supplier in writing of any claims arising under this warranty. Upon receipt of such notice, the Supplier shall, within the period specified in the **SCC** and with all reasonable speed, repair or replace the defective Goods or parts thereof, without cost to the Procuring Entity.
- 17.5. If the Supplier, having been notified, fails to remedy the defect(s) within the period specified in **GCC** Clause 17.4, the Procuring Entity may proceed to take such remedial action as may be necessary, at the Supplier's risk and expense and without prejudice to any other rights which the Procuring Entity may have against the Supplier under the Contract and under the applicable law.

18. Delays in the Supplier's Performance

- 18.1. Delivery of the Goods and/or performance of Services shall be made by the Supplier in accordance with the time schedule prescribed by the Procuring Entity in Section VI. Schedule of Requirements.
- 18.2. If at any time during the performance of this Contract, the Supplier or its Subcontractor(s) should encounter conditions impeding timely delivery of the Goods and/or performance of Services, the Supplier shall promptly notify the Procuring Entity in writing of the fact of the delay, its likely duration and its cause(s). As soon as practicable after receipt of the Supplier's notice, and upon causes provided for under **GCC** Clause 22, the Procuring Entity shall evaluate the situation and may extend the Supplier's time for performance, in which case the extension shall be ratified by the parties by amendment of Contract.
- 18.3. Except as provided under **GCC** Clause 22, a delay by the Supplier in the performance of its obligations shall render the Supplier liable to the imposition of liquidated damages pursuant to **GCC** Clause 19, unless an extension of time is agreed upon pursuant to **GCC** Clause 29 without the application of liquidated damages.

19. Liquidated Damages

Subject to **GCC** Clauses 18 and 22, if the Supplier fails to satisfactorily deliver any or all of the Goods and/or to perform the Services within the period(s) specified in this Contract

inclusive of duly granted time extensions if any, the Procuring Entity shall, without prejudice to its other remedies under this Contract and under the applicable law, deduct from the Contract Price, as liquidated damages, the applicable rate of one tenth (1/10) of one (1) percent of the cost of the unperformed portion for every day of delay until actual delivery or performance. The maximum deduction shall be ten percent (10%) of the amount of contract. Once the maximum is reached, the Procuring Entity may rescind or terminate the Contract pursuant to **GCC** Clause 23, without prejudice to other courses of action and remedies open to it.

20. Settlement of Disputes

- 20.1. If any dispute or difference of any kind whatsoever shall arise between the Procuring Entity and the Supplier in connection with or arising out of this Contract, the parties shall make every effort to resolve amicably such dispute or difference by mutual consultation.
- 20.2. If after thirty (30) days, the parties have failed to resolve their dispute or difference by such mutual consultation, then either the Procuring Entity or the Supplier may give notice to the other party of its intention to commence arbitration, as hereinafter provided, as to the matter in dispute, and no arbitration in respect of this matter may be commenced unless such notice is given.
- 20.3. Any dispute or difference in respect of which a notice of intention to commence arbitration has been given in accordance with this Clause shall be settled by arbitration. Arbitration may be commenced prior to or after delivery of the Goods under this Contract.
- 20.4. In the case of a dispute between the Procuring Entity and the Supplier, the dispute shall be resolved in accordance with Republic Act 9285 (“R.A. 9285”), otherwise known as the “Alternative Dispute Resolution Act of 2004.”
- 20.5. Notwithstanding any reference to arbitration herein, the parties shall continue to perform their respective obligations under the Contract unless they otherwise agree; and the Procuring Entity shall pay the Supplier any monies due the Supplier.

21. Liability of the Supplier

- 21.1. The Supplier’s liability under this Contract shall be as provided by the laws of the Republic of the Philippines, subject to additional provisions, if any, set forth in the **SCC**.
- 21.2. Except in cases of criminal negligence or wilful misconduct, and in the case of infringement of patent rights, if applicable, the aggregate liability of the Supplier to the Procuring Entity shall not exceed the total Contract Price, provided that this limitation shall not apply to the cost of repairing or replacing defective equipment.

22. Force Majeure

- 22.1. The Supplier shall not be liable for forfeiture of its performance security, liquidated damages, or termination for default if and to the extent that the Supplier's delay in performance or other failure to perform its obligations under the Contract is the result of a *force majeure*.
- 22.2. For purposes of this Contract the terms "*force majeure*" and "fortuitous event" may be used interchangeably. In this regard, a fortuitous event or *force majeure* shall be interpreted to mean an event which the Supplier could not have foreseen, or which though foreseen, was inevitable. It shall not include ordinary unfavourable weather conditions; and any other cause the effects of which could have been avoided with the exercise of reasonable diligence by the Supplier. Such events may include, but not limited to, acts of the Procuring Entity in its sovereign capacity, wars or revolutions, fires, floods, epidemics, quarantine restrictions, and freight embargoes.
- 22.3. If a *force majeure* situation arises, the Supplier shall promptly notify the Procuring Entity in writing of such condition and the cause thereof. Unless otherwise directed by the Procuring Entity in writing, the Supplier shall continue to perform its obligations under the Contract as far as is reasonably practical, and shall seek all reasonable alternative means for performance not prevented by the *force majeure*.

23. Termination for Default

- 23.1. The Procuring Entity shall terminate this Contract for default when any of the following conditions attends its implementation:
 - (a) Outside of *force majeure*, the Supplier fails to deliver or perform any or all of the Goods within the period(s) specified in the contract, or within any extension thereof granted by the Procuring Entity pursuant to a request made by the Supplier prior to the delay, and such failure amounts to at least ten percent (10%) of the contract price;
 - (b) As a result of *force majeure*, the Supplier is unable to deliver or perform any or all of the Goods, amounting to at least ten percent (10%) of the contract price, for a period of not less than sixty (60) calendar days after receipt of the notice from the Procuring Entity stating that the circumstance of force majeure is deemed to have ceased; or
 - (c) The Supplier fails to perform any other obligation under the Contract.
- 23.2. In the event the Procuring Entity terminates this Contract in whole or in part, for any of the reasons provided under GCC Clauses 23 to 26, the Procuring Entity may procure, upon such terms and in such manner as it deems appropriate, Goods or Services similar to those undelivered, and the Supplier shall be liable to the Procuring Entity for any excess costs for such similar Goods or Services. However,

the Supplier shall continue performance of this Contract to the extent not terminated.

- 23.3. In case the delay in the delivery of the Goods and/or performance of the Services exceeds a time duration equivalent to ten percent (10%) of the specified contract time plus any time extension duly granted to the Supplier, the Procuring Entity may terminate this Contract, forfeit the Supplier's performance security and award the same to a qualified Supplier.

24. Termination for Insolvency

The Procuring Entity shall terminate this Contract if the Supplier is declared bankrupt or insolvent as determined with finality by a court of competent jurisdiction. In this event, termination will be without compensation to the Supplier, provided that such termination will not prejudice or affect any right of action or remedy which has accrued or will accrue thereafter to the Procuring Entity and/or the Supplier.

25. Termination for Convenience

- 25.1. The Procuring Entity may terminate this Contract, in whole or in part, at any time for its convenience. The HoPE may terminate a contract for the convenience of the Government if he has determined the existence of conditions that make Project Implementation economically, financially or technically impractical and/or unnecessary, such as, but not limited to, fortuitous event(s) or changes in law and national government policies.
- 25.2. The Goods that have been delivered and/or performed or are ready for delivery or performance within thirty (30) calendar days after the Supplier's receipt of Notice to Terminate shall be accepted by the Procuring Entity at the contract terms and prices. For Goods not yet performed and/or ready for delivery, the Procuring Entity may elect:
- (a) to have any portion delivered and/or performed and paid at the contract terms and prices; and/or
 - (b) to cancel the remainder and pay to the Supplier an agreed amount for partially completed and/or performed goods and for materials and parts previously procured by the Supplier.
- 25.3. If the Supplier suffers loss in its initial performance of the terminated contract, such as purchase of raw materials for goods specially manufactured for the Procuring Entity which cannot be sold in open market, it shall be allowed to recover partially from this Contract, on a *quantum meruit* basis. Before recovery may be made, the fact of loss must be established under oath by the Supplier to the satisfaction of the Procuring Entity before recovery may be made.

26. Termination for Unlawful Acts

26.1. The Procuring Entity may terminate this Contract in case it is determined *prima facie* that the Supplier has engaged, before or during the implementation of this Contract, in unlawful deeds and behaviours relative to contract acquisition and implementation. Unlawful acts include, but are not limited to, the following:

- (a) Corrupt, fraudulent, and coercive practices as defined in **ITB** Clause 3.1(a);
- (b) Drawing up or using forged documents;
- (c) Using adulterated materials, means or methods, or engaging in production contrary to rules of science or the trade; and
- (d) Any other act analogous to the foregoing.

27. Procedures for Termination of Contracts

27.1. The following provisions shall govern the procedures for termination of this Contract:

- (a) Upon receipt of a written report of acts or causes which may constitute ground(s) for termination as aforementioned, or upon its own initiative, the Implementing Unit shall, within a period of seven (7) calendar days, verify the existence of such ground(s) and cause the execution of a Verified Report, with all relevant evidence attached;
- (b) Upon recommendation by the Implementing Unit, the HoPE shall terminate this Contract only by a written notice to the Supplier conveying the termination of this Contract. The notice shall state:
 - (i) that this Contract is being terminated for any of the ground(s) aforementioned, and a statement of the acts that constitute the ground(s) constituting the same;
 - (ii) the extent of termination, whether in whole or in part;
 - (iii) an instruction to the Supplier to show cause as to why this Contract should not be terminated; and
 - (iv) special instructions of the Procuring Entity, if any.
- (c) The Notice to Terminate shall be accompanied by a copy of the Verified Report;
- (d) Within a period of seven (7) calendar days from receipt of the Notice of Termination, the Supplier shall submit to the HoPE a verified position paper stating why this Contract should not be terminated. If the Supplier fails to

show cause after the lapse of the seven (7) day period, either by inaction or by default, the HoPE shall issue an order terminating this Contract;

- (e) The Procuring Entity may, at any time before receipt of the Supplier's verified position paper described in item (d) above withdraw the Notice to Terminate if it is determined that certain items or works subject of the notice had been completed, delivered, or performed before the Supplier's receipt of the notice;
- (f) Within a non-extendible period of ten (10) calendar days from receipt of the verified position paper, the HoPE shall decide whether or not to terminate this Contract. It shall serve a written notice to the Supplier of its decision and, unless otherwise provided, this Contract is deemed terminated from receipt of the Supplier of the notice of decision. The termination shall only be based on the ground(s) stated in the Notice to Terminate;
- (g) The HoPE may create a Contract Termination Review Committee (CTRC) to assist him in the discharge of this function. All decisions recommended by the CTRC shall be subject to the approval of the HoPE; and
- (h) The Supplier must serve a written notice to the Procuring Entity of its intention to terminate the contract at least thirty (30) calendar days before its intended termination. The Contract is deemed terminated if it is not resumed in thirty (30) calendar days after the receipt of such notice by the Procuring Entity.

28. Assignment of Rights

The Supplier shall not assign his rights or obligations under this Contract, in whole or in part, except with the Procuring Entity's prior written consent.

29. Contract Amendment

Subject to applicable laws, no variation in or modification of the terms of this Contract shall be made except by written amendment signed by the parties.

30. Application

These General Conditions shall apply to the extent that they are not superseded by provisions of other parts of this Contract.

Section V. Special Conditions of Contract

Special Conditions of Contract

GCC Clause	
1.1(g)	The Procuring Entity is <i>Camarines Norte Electric Cooperative, Inc. (CANORECO)</i>
1.1(i)	The Supplier is _____
1.1(j)	The Funding Source is <i>DPWH Fund.</i>
1.1(k)	The Project Site is <i>CANORECO Warehouse, Barangay San Isidro, Talisay, Camarines Norte.</i>
2.1	No further instructions.
5.1	<p>The Procuring Entity’s address for Notices is:</p> <p style="text-align: center;">ZANDRO R. GESTIADA</p> <p style="text-align: center;"><i>General Manager</i></p> <p style="text-align: center;"><i>Camarines Norte Electric Cooperative, Inc. (CANORECO)</i></p> <p style="text-align: center;"><i>Jose P. Rizal Street, Barangay I, Daet, Camarines Norte 4600</i></p> <p style="text-align: center;"><i>(054) 571-3796/571-3717</i></p> <p>The Supplier’s address for Notices is:</p> <p style="text-align: center;">_____</p>
6.1	<p>Delivery and Documents –</p> <p>For purposes of the Contract, “EXW,” “FOB,” “FCA,” “CIF,” “CIP,” “DDP” and other trade terms used to describe the obligations of the parties shall have the meanings assigned to them by the current edition of INCOTERMS published by the International Chamber of Commerce, Paris. The Delivery terms of this Contract shall be as follows:</p> <p>The delivery terms applicable to this Contract are delivered <i>at CANORECO Warehouse, Barangay San Isidro, Talisay, Camarines Norte.</i> Risk and title will pass from the Supplier to the Procuring Entity upon receipt and final acceptance of the Goods at their final destination.</p> <p>Delivery of the Goods shall be made by the Supplier in accordance with the terms specified in</p>

. The details of shipping and/or other documents to be furnished by the Supplier are as follows:

Upon delivery of the Goods to the Project Site, the Supplier shall notify the Procuring Entity and present the following documents to the Procuring Entity:

- (i) Original and four copies of the Supplier's invoice showing Goods' description, quantity, unit price, and total amount;
- (ii) Original and four copies delivery receipt/note, railway receipt, or truck receipt;
- (iii) Original Supplier's factory inspection report;
- (iv) Original and four copies of the Manufacturer's and/or Supplier's warranty certificate;
- (v) Original and four copies of the certificate of origin (for imported Goods);
- (vi) Delivery receipt detailing number and description of items received signed by the authorized receiving personnel;
- (vii) Certificate of Acceptance/Inspection Report signed by the Procuring Entity's representative at the Project Site; and
- (viii) Four copies of the Invoice Receipt for Property signed by the Procuring Entity's representative at the Project Site.

For purposes of this Clause the Procuring Entity's Representative at the Project Site is ***Faustino L. Mendiola, Jr., Warehousing Section Head***

Incidental Services –

The Supplier is required to provide all of the following services, including additional services, if any, specified in:

- (a) performance or supervision of on-site assembly and/or start-up of the supplied Goods;
- (b) furnishing of tools required for assembly and/or maintenance of the supplied Goods;
- (c) furnishing of a detailed operations and maintenance manual for each appropriate unit of the supplied Goods;
- (d) performance or supervision or maintenance and/or repair of the supplied Goods, for a period of time agreed by the parties, provided that this service shall not relieve the Supplier of any warranty obligations under this Contract; and

(e) training of the Procuring Entity's personnel, at the Supplier's plant and/or on-site, in assembly, start-up, operation, maintenance, and/or repair of the supplied Goods.

The Contract price for the Goods shall include the prices charged by the Supplier for incidental services and shall not exceed the prevailing rates charged to other parties by the Supplier for similar services.

Packaging –

The Supplier shall provide such packaging of the Goods as is required to prevent their damage or deterioration during transit to their final destination, as indicated in this Contract. The packaging shall be sufficient to withstand, without limitation, rough handling during transit and exposure to extreme temperatures, salt and precipitation during transit, and open storage. Packaging case size and weights shall take into consideration, where appropriate, the remoteness of the GOODS' final destination and the absence of heavy handling facilities at all points in transit.

The packaging, marking, and documentation within and outside the packages shall comply strictly with such special requirements as shall be expressly provided for in the Contract, including additional requirements, if any, specified below, and in any subsequent instructions ordered by the Procuring Entity.

The outer packaging must be clearly marked on at least four (4) sides as follows:

Name of the Procuring Entity:

Name of the Supplier

Contract Description

Final Destination

Gross weight

Any special lifting instructions

Any special handling instructions

Any relevant HAZCHEM classifications

A packaging list identifying the contents and quantities of the package is to be placed on an accessible point of the outer packaging if practical. If not practical the packaging list is to be placed inside the outer packaging but outside the secondary packaging.

Insurance –

The Goods supplied under this Contract shall be fully insured by the Supplier in a freely convertible currency against loss or damage incidental to manufacture or acquisition, transportation, storage, and delivery. The Goods remain at the risk and title of the Supplier until their final acceptance by the Procuring Entity.

Transportation –

Where the Supplier is required under Contract to deliver the Goods CIF, CIP or DDP, transport of the Goods to the port of destination or such other named place of destination in the Philippines, as shall be specified in this Contract, shall be arranged and paid for by the Supplier, and the cost thereof shall be included in the Contract Price.

Where the Supplier is required under this Contract to transport the Goods to a specified place of destination within the Philippines, defined as the Project Site, transport to such place of destination in the Philippines, including insurance and storage, as shall be specified in this Contract, shall be arranged by the Supplier, and related costs shall be included in the Contract Price.

Where the Supplier is required under Contract to deliver the Goods CIF, CIP or DDP, Goods are to be transported on carriers of Philippine registry. In the event that no carrier of Philippine registry is available, Goods may be shipped by a carrier which is not of Philippine registry provided that the Supplier obtains and presents to the Procuring Entity certification to this effect from the nearest Philippine consulate to the port of dispatch. In the event that carriers of Philippine registry are available but their schedule delays the Supplier in its performance of this Contract the period from when the Goods were first ready for shipment and the actual date of shipment the period of delay will be considered *force majeure* in accordance with **GCC** Clause 22.

The Procuring Entity accepts no liability for the damage of Goods during transit other than those prescribed by INCOTERMS for DDP Deliveries. In the case of Goods supplied from within the Philippines or supplied by domestic Suppliers risk and title will not be deemed to have passed to the Procuring Entity until their receipt and final acceptance at the final destination.

	<p>Patent Rights –</p> <p>The Supplier shall indemnify the Procuring Entity against all third-party claims of infringement of patent, trademark, or industrial design rights arising from use of the Goods or any part thereof.</p>
10.4	Not applicable
10.5	Payment using LC is not allowed
11.3	Maintain the GCC Clause
13.4(c)	No further instructions
16.1	Actual inspection of materials during post-qualification process to determine quality of actual materials to be delivered.
17.3	One (1) year after acceptance by the Procuring Entity of the delivered Goods.
17.4	The period for correction of defects in the warranty period is <i>thirty (30) days</i> .
21.1	No additional provision

Section VI. Schedule of Requirements

The delivery schedule expressed as weeks/months stipulates hereafter a delivery date which is the date of delivery to the project site.

Item Number	Description	Quantity	Total	Delivered, Weeks/Months
1	Attachment Guy Malleable Iron	pcs	233	
2	Bolt Carriage 3/8" x 4-1/2"	pcs	330	
3	Bolt Double Arming 5/8 x 20	pcs	9	
4	Bolt Double Arming 5/8 x 22	pcs	226	
5	Bolt Double Arming 5/8 x 24	pcs	161	
6	Bolt Double Arming 5/8 x 26	pcs	6	
7	Bolt Double Upset 5/8 x 10	pcs	29	
8	Bolt Eye Oval 5/8 x 9	pcs	60	
9	Bolt Eye Oval 5/8 x 10	pcs	182	
10	Bolt Eye Oval 5/8 x 12	pcs	420	
11	Bolt Eye Oval 5/8 x 18	pcs	204	
12	Machine Bolt 1/2 x 8	pcs	2	
13	Machine Bolt 1/2 x 10	pcs	631	
14	Machine Bolt 1/2 x 12	pcs	124	
15	Machine Bolt 5/8 x 8	pcs	159	
16	Machine Bolt 5/8 x 10	pcs	551	
17	Machine Bolt 5/8 x 12	pcs	60	
18	Machine Bolt 5/8 x 14	pcs	85	
19	Machine Bolt 5/8 x 16	pcs	540	
20	Bolt Single Upset 5/8 x 8	pcs	3	
21	Bolt Single Upset 5/8 x 10	pcs	38	
22	Bolt Single Upset 5/8 x 12	pcs	4	
23	Brace Crossarm Steel 28 Span	pcs	330	
24	Brace Crossarm Steel Angle Steel	pcs	62	
25	Brace Sidearm Vertical	pcs	328	
26	Brace Sidearm Diagonal, 7 ft.	pcs	328	
27	Bracket Clevis Deadend w/o Spool	pcs	312	
28	Connector Hotline Clamp 2-4/0	pcs	166	
29	Clamp Anchor Rod Bonding Single Eye	pcs	97	
30	Clamp Loop Deadend #6 2/0 ACSR	pcs	676	
31	Clamp Cond Deadend Strain 4-4/0	pcs	483	
32	Clamp Guy 3 Bolt	pcs	490	
33	Clamp Suspension Alloy 2/0	pcs	52	
34	Clamp Guy Bond	pcs	136	

35	Clevis Secondary Swinging	pcs	387	
36	Shackle Anchor	pcs	271	
37	Conductor Bare ACSR #2	mtrs	15,044	
38	Conductor Bare ACSR #1/0	mtrs	48,835	
39	Conductor Bare ACSR #4/0	mtrs	100,551	
40	Conductor Duplex #2	mtrs	374	
41	Connector Compression YHO 150	pcs	921	
42	Connector Compression YHO 200	pcs	89	
43	Connector Compression YHO 300	pcs	85	
44	Connector Compression YHO 400	pcs	236	
45	Connector Ground Rod Clamp	pcs	172	
46	Pin Crossarm Long Shunk	pcs	1,514	
47	Fuse Cutout & Arrester Comb.	set	76	
48	Guy Hook	pcs	20	
49	Insulator Pin Type 55-5	pcs	1,665	
50	Insulator Spool 1 3/4	pcs	153	
51	Insulator Spool 3	pcs	620	
52	Insulator Suspension	pcs	1,114	
53	Nut Eye Conventional 5/8	pcs	510	
54	Nut Lock 3/8	pcs	330	
55	Nut Lock 1/2	pcs	1,210	
56	Nut lock 5/8	pcs	3,649	
57	Pin Pole Top	pcs	118	
58	Rod Anchor Threaded Single Eye	pcs	197	
59	Rod Ground Steel 5/8 x 10	pcs	172	
60	Lug terminal #2	pcs	260	
61	Spacer Pipe	pcs	52	
62	Washer Square Flat 2 1/4 x 2 1/4	pcs	3,902	
63	Washer Square Flat 4 x 4	pcs	197	
64	Washer Round	pcs	1,210	
65	Tie Wire	ft	15,352	
66	Aarmor Tape 05 x .30	ft	439	
67	Ground Wire Alum. Alloy #4-3 Strand	ft	8,158	
68	Guy Wire	ft	12,380	
69	Steel Pole 30ft	pcs	25	
70	Steel Pole 40ft	pcs	414	
71	Steel Pole 45ft	pcs	111	

72	Steel Pole 50ft	pcs	14	
73	Anchor Log	pcs	197	
74	Crossarm Steel 8ft	pcs	928	
75	Crossarm Steel 10ft	pcs	22	
76	Insulator Post Type, Porcelain w/7 Stud	pcs	2	
77	Clamp, Suspension, Alum Alloy Clevis 2 bolts	pcs	15	
78	Clamp Groud Wire, Deadend Strain Clevis	pcs	2	
79	Truss Guy Down Guy	pcs	2	

Section VII. Technical Specifications

TECHNICAL SPECIFICATIONS OF MATERIALS

ATTACHMENT, GUY, MALLEABLE TYPE WITH 11/16" HOLE DIAMETER

Max Strand	45°; Ultimate Str. (Lbs.)	Bolt Hole Dia.	Weight/100 (lbs.)
1/2	13,550	11/16	105
9/16	20,050	13/16	120

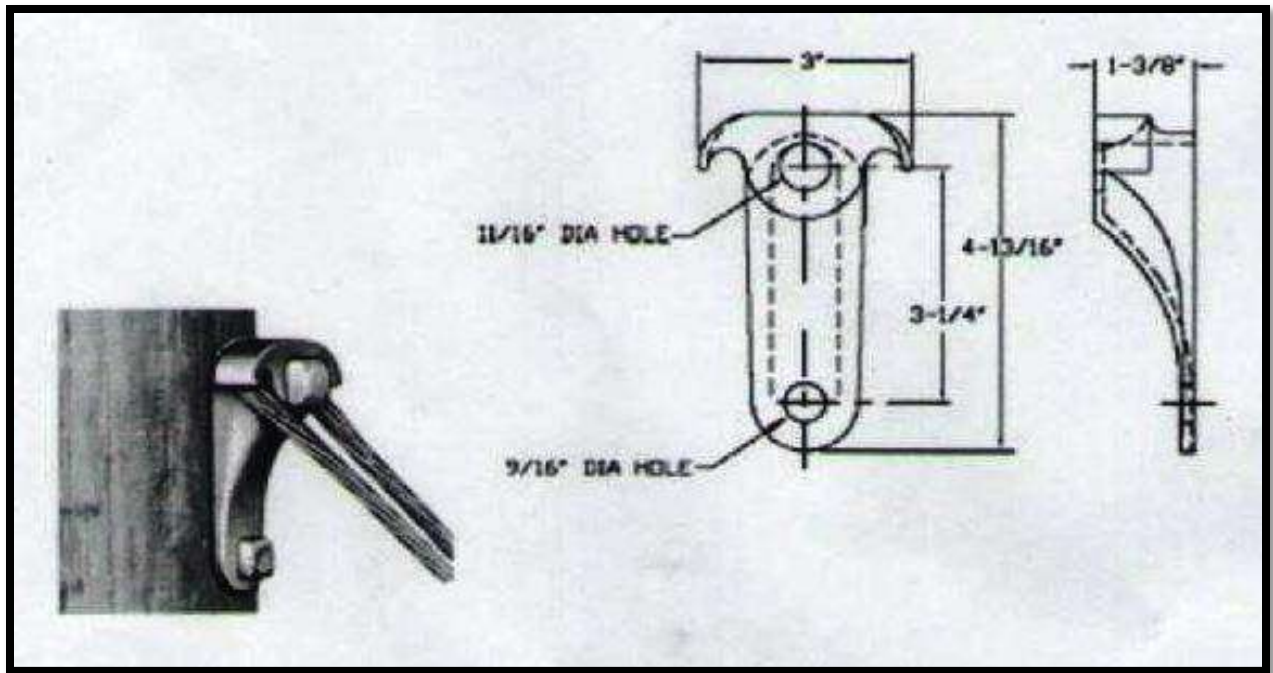

BOLTS, UPSET DOUBLE

It includes square nut, round washer and cotter key on short end and Square nut and M-F locknut on long end. It is used with spool insulators ANSI 53-2. Hot dip galvanized.

Dimensions in Inches		
A	L	B
8	13 ³ / ₄	6
9	14 ³ / ₄	6
10	15 ³ / ₄	6
12	17 ³ / ₄	6
14	19 ³ / ₄	6

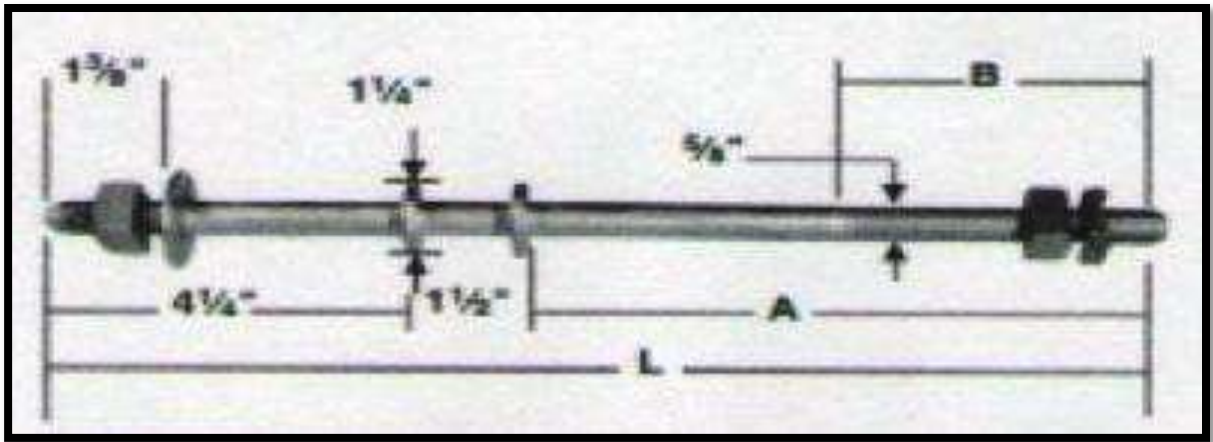

BOLT, OVAL EYE (5/8" X 9"; 5/8" X 10"; 5/8" X 18")

Bolts with 5/8" and 3/4" shanks have 1 1/2" x 2" oval eyes. Drop-forged, galvanized steel bolts have cone type points and rolled threads. It is commonly used as an attachment point to secure thimbles, clevises, links and dead end insulators. Regular oval eye bolts are supplied with a 4 or 6-inch thread length and one assembled square nut.



Length Under Eye (Inches)	Thread Length (Inches)	Approx. Ship Wt. Lbs. (Per 100 Pcs.)
6	4	100
8	4	104
9	4	113
10	6	122
12	6	144
14	6	146
16	6	168
18	6	208
20	6	240

BOLT, MACHINE (1/2" X 8"; 5/8" X 8"; 5/8 X 10"; 5/8" X 12"; 5/8 X 14")

Are also called cross arm bolts or through bolts. Bolts have the following features.

FEATURES:

- Square head and square nut;
- Roll threaded;
- Bolts 1/2" diameter and larger and 7" length and longer also have cone points which permit driving without damage to threads.

MATERIAL:

- Steel hot dip galvanized.



Dim. In Inches (1/2-Inch Diameter)		Approx. Ship Wt. Lbs. (Per 100 Pcs.)
Bolt Length	Thread Length	
1 1/2	1 1/4	17.6
4 1/2	3	33
5	3	35
6	3	39
7	3	48
8	4	49
9	4	57
10	4	60
12	6	71
14	6	73

BOLT, SINGLE UPSET (5/8" X 8"; 5/8 X 10")

Used in rural secondary construction. Has 5/8" thread diameter. Used with spool insulators ANSI 53-2. Hot dip galvanized.

Dim. In Inches (5/8-Inch Diameter)		Approx. Ship Wt. Lbs. (Per 100 Pcs.)
Bolt Length	Thread Length	
5	3	60
6	3	69
7	4	75
8	4	78
9	4	84
10	6	99
12	6	112
14	6	126
16	6	134
18	6	149
20	6	164
22	6	176
24	6	194

Dimension in Inches			Approx. Ship Wt. Lbs. (Per 100 Pcs.)
Shank Length		B	
A	L		
8	12 3/4	4	138
9	13 3/4	4	144
10	14 3/4	4	170
12	16 3/4	6	186
14	18 3/4	6	196

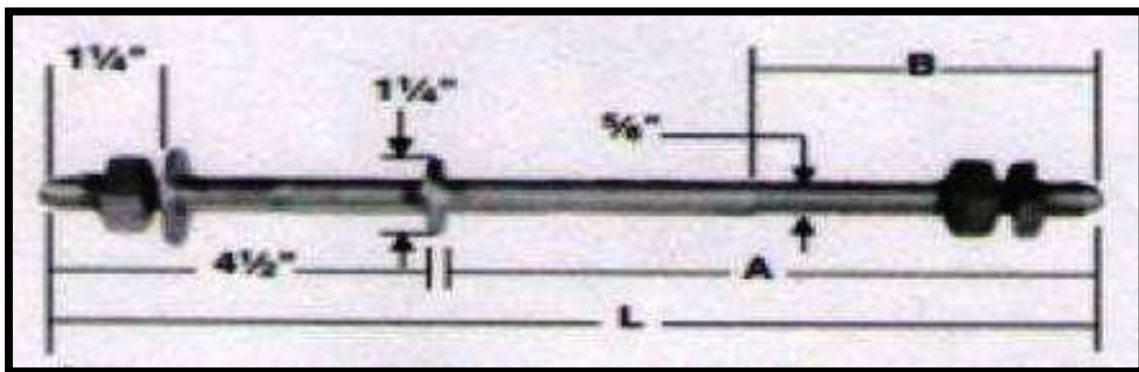

BOLT, CARRIAGE 3/8" X 4-1/2"

Carriage Bolts have square nuts, finished points and rolled threads. Standard have square shoulders. Open-hearth steel. Hot dip galvanized.

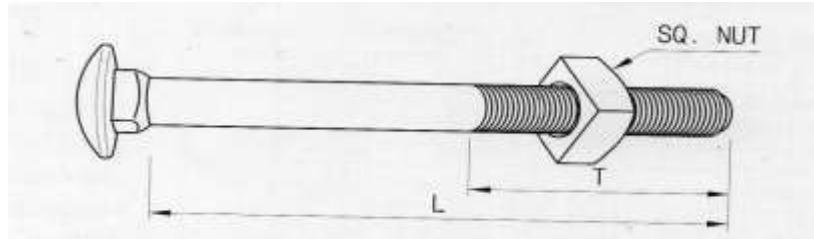

BRACE, CROSSARM, 28", STEEL OR WOOD

Have rounded ends and are punched at one end with a 14 mm hole, with 11 mm hole at the other end. Holes punched 25mm from brace end to center of hole. Hot Dip Galvanized.



L MM (Inch)	A (MM)	Standard Unit Weight (pc) (kg)	Standard Pieces Per Box/Bundle
660(26)	610		10
711 (28)	660	1.08	10
762 (30)	711	1.13	10
813 (32)	762	1.21	10

CLAMP, HOT LINE, #2 - #2/0 ACSR MAIN TO #2 - #2/0

For Aluminum, ACSR and armor rod covered aluminum or ACSR conductor. For installation on energized conductor.

- **Body and Keeper** – Aluminum Alloy;
- **Eyebolt** – Bronze Alloy – Tin Plated;
- **Eyestem** – Bronze Alloy, Forged or Stainless Steel; and
- **Spring (on eyestem)** – Stainless Steel

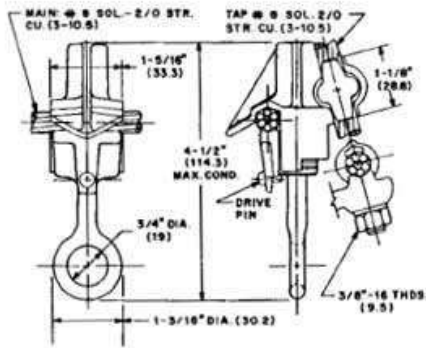

FIGURE 1 (BC)

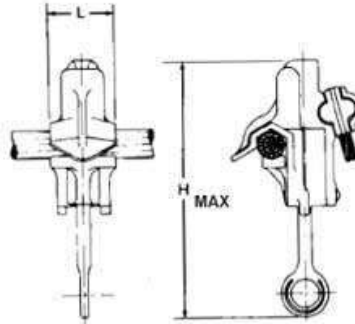

FIGURE 2 (BH)

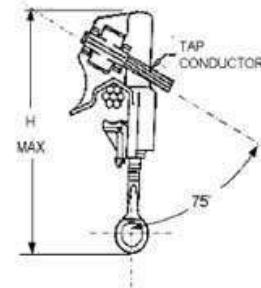
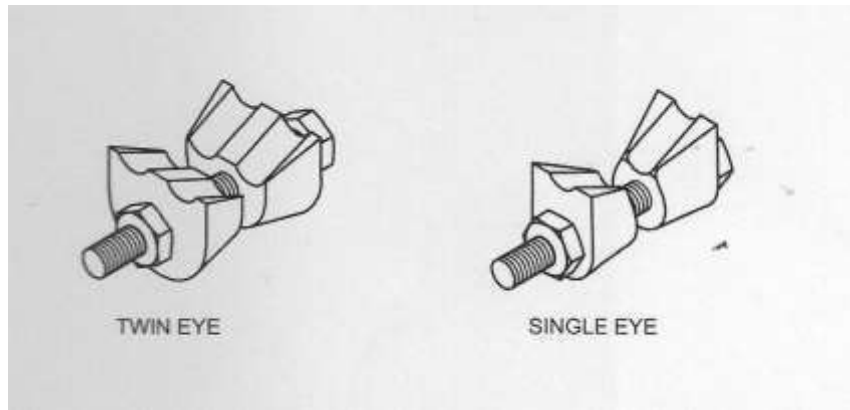

FIGURE 3 (S1530CC/S1540CC)

CLAMP, ANCHOR, ROD BONDING, SINGLE EYE

Bonding Clamps provide dependable mechanical and electrical pressure contact between guy strand and anchor rod when the guy is part of the grounding system. It is used in thimble eye and angle thimble eye bolts to keep hardware-to-guy contacts tight. Also used to prevent excessive wear on guy strands and protect galvanized coating. It maintains electrical continuity.



CLAMP, LOOP DEADEND, #2 ACSR

High Strength Aluminum Casting with galvanized steel U-Bolt, extra-long soft aluminum spacer and caps that confine strands. Holding strength using two dead end clamps exceeds rated breaking strength of conductors.

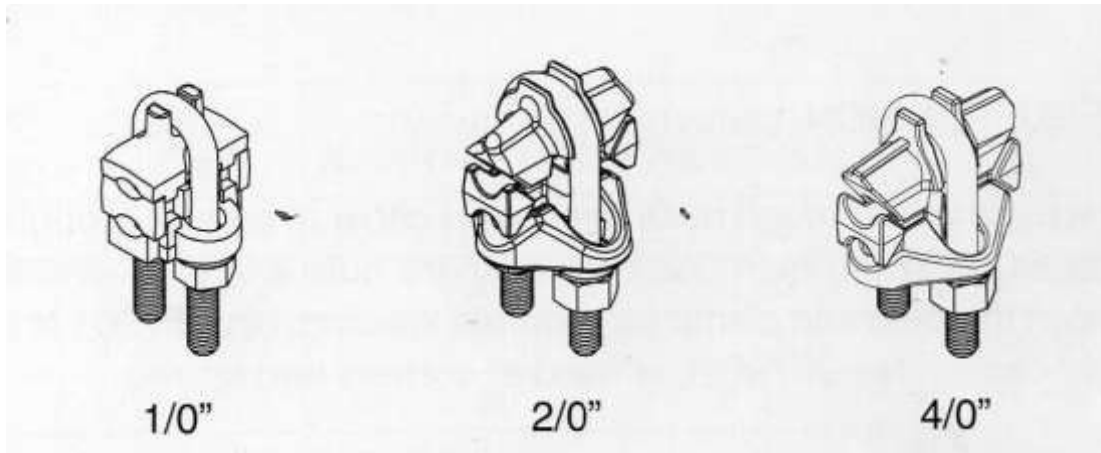

Size	Standard Unit Weight (Ass'y) (kg)	Standard Pieces Per Box/Bundle
1/2	0.08	100
2/0	0.17	50
4/0	0.39	50

CLAMP, DEADEND STRAIN, #1/0 ACSR

Clamp bodies and keeper pieces should be casted in high strength aluminum alloy that is non-copper bearing. U-bolts, clevis pin and associated components should be made of steel. Cotter keys are stainless steel. Socket eye and clevis used as connectors are ductile iron of great strength.

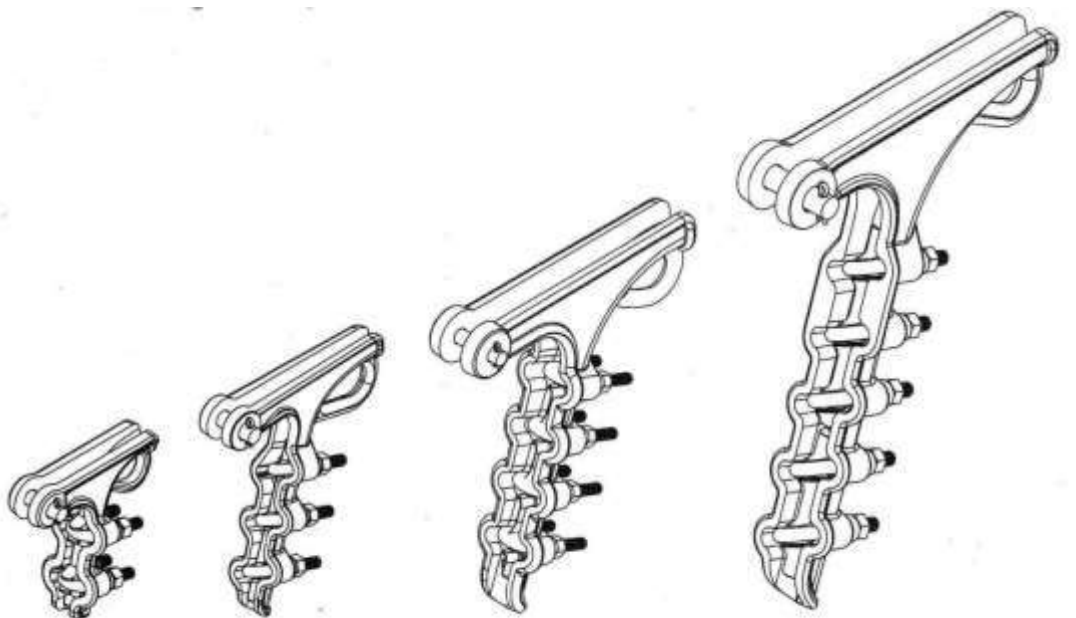

CLAMP, GUY STRAIGHT, 3 BOLT, HEAVY DUTY STEEL

Parallel grooves tap strand tightly without marring. Plate halves align evenly for easy application. Each bolt has a shoulder to prevent turning while tightening. Hot Dip Galvanized.

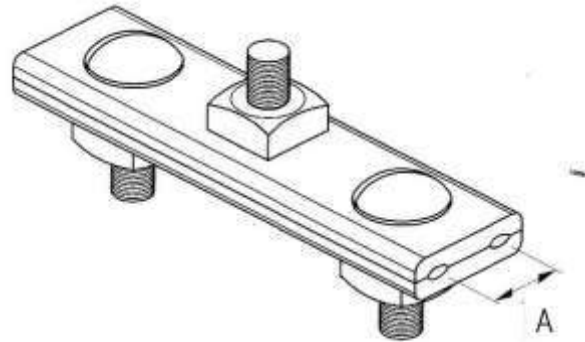

3-BOLTS

CLEVIS SECONDARY SWINGING WITHOUT SPOOL

Secondary Swinging Clevis is used for attaching to oval eye bolt or eye nut giving flexible mounting for equalizing strain at corners.

FEATURES:

- Clevis mounting holes are for 5/8" bolts;
- Mounting holes are slotted to permit installation without removing insulators;
- Includes mounting slot for one 5/8" machine bolt and two staggered side holes for 1/2" lag screws.

MATERIAL: Steel hot dip galvanized.

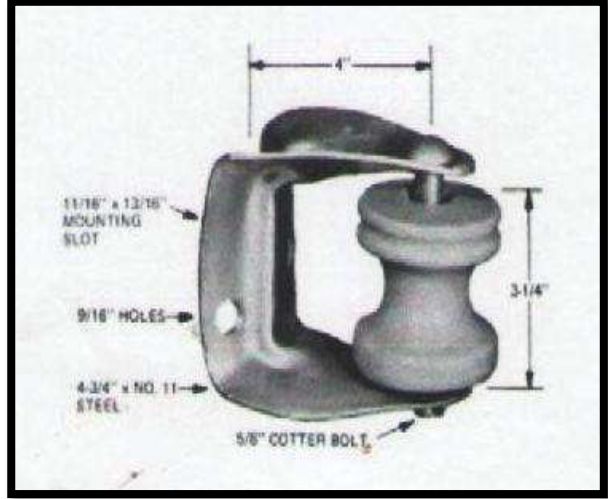
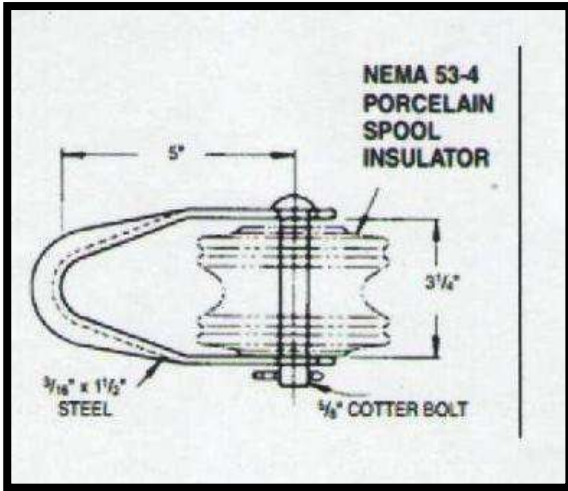

SHACKLE, ANCHOR, FORGED STEEL, GALVANIZED

Used principally for attaching suspension-insulator units to the pole. Drop forged. Hot Dip Galvanized. RUS Load Rating: 20,000 lbs.

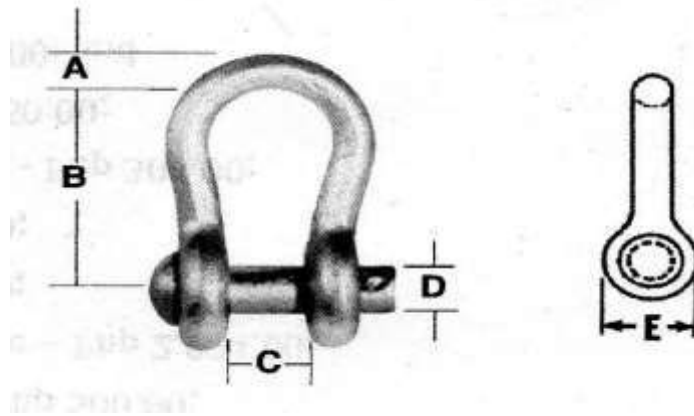

Dimensions in Inches					Approx. Ship. Wt. Lbs. Per 100 Pcs.
A	B	C	D	E	
1/2	2 1/2	3/4	5/8	1 5/8	

(CONDUCTOR, BARE, ACSR #4/0, AWG 6/1 & CONDUCTOR, BARE, ACSR #2/0, AWG 6/1)

GENERAL: ACSR conductors shall conform in all respects to the dimensional and performance requirements of this document, which covers:

1. Steel core wire
2. Aluminum wire

The ACSR conductors shall be classified as Class A as designated in American Society for testing and materials B232.

STEEL CORE

MATERIAL: The steel wire shall be fabricated from steel obtained by the open-hearth, electric furnace, of basic oxygen process and conforms to the chemical composition specified in Section 3 of ASTM B498.

TESTING: The steel wire shall be tested in accordance with Section 5, 6 and 10 of ASTM B498.

CORROSION PROTECTION: The steel wire shall be coated with zinc to Class A requirement with coating weight described in Table 4 of ASTM B498.

Additional protection for ACSR conductor against corrosion of the steel core shall be provided by use of a suitable corrosion inhibition, grease or oil.

ALUMINUM WIRES

MATERIALS: The round aluminum wire shall be drawn from rods that conform to the chemical requirement of Table 2, ASTM B230.

TESTING: The aluminum wire shall have tensile strengths depending on temper as shown in Table 1 of ASTM B233.

RESISTIVITY: The electrical resistivity limits and values of the aluminum rods are presented in Table 4 of ASTM B230.

LAY FACTOR: The lay factor of the aluminum wire shall be not less than 12 or more than 14.5 times the outside diameter of the conductor. The preferred lay factor is 13 times the diameter, with the lay in a right hand direction.

CONSTRUCTION: The number and diameter of aluminum and steel wires and the stranding shall conform to the requirements of Table 1, 2 and 3 of ASTM B232.

CONDUCTOR STRENGTH: The rated strength shall be the aggregate strength of the steel and aluminum wires determined by the methods described in Section 9.1 of ASTM B232.

WEIGHT AND ELECTRICAL RESISTANCE: The weight and electrical resistance of the stranded conductor shall be determined by the methods described in the Section 11 of ASTM B233.

CHARACTERISTICS: ACSR conductors shall have the following characteristic:

FINISH: The conductor shall be free of imperfections, sharp protrusions and blemishes not consistent with good commercial practice.

TESTS AND INSPECTION: The manufacturer shall conduct conductor tests and inspections in accordance with Section 16 of ASTM B232 of IEC 888, in so far as applicable. CANORECO reserves the right to witness factory tests and inspections and shall request test reports. The manufacturer shall also conduct reel tests and inspections and submit test reports before shipment to verify that the reel and lagging comply with the requirements of this Standard. CANORECO shall also have the prerogative to inspect conductor reels at any time to ensure compliance of this standard. Non-conforming reels and lagging are unacceptable.

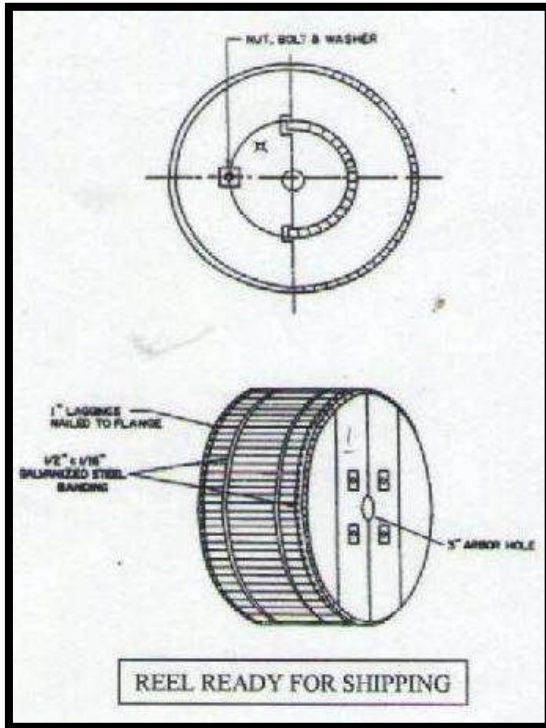

PACKAGING AND SHIPPING: Conductor shall be shipped in a non-returnable reels manufactured from “aluminum steel” or export quality preservative treated wood lagging. Wood reels and all lagging shall be constructed from new lumber which shall be square sawn, be of smooth surface, with not splits, warps, crooks, loose fibers, decay or insect infestation. The lumber used for wood reels and all lagging shall be preservative treated in accordance with “American Wood Preserves Association Standards”.

(CONDUCTOR, INSULATED, ACSR #2/0, AWG 6/1)

SCOPE: This standard establishes the dimensional and performance requirements of bare coated steel-reinforced concentric-lay-stranded aluminum conductors (ACSR), **Cross linked Polyethylene insulated (black colored), 600V** to be used on Coop distribution lines. This conductor is made of round aluminum wires wrapped around a central zinc-coated round steel-wire core.

GENERAL: ACSR conductors shall conform in all respects to the dimensional and performance requirements of these documents, which covers:

1. **Steel Core Wire**
2. **Aluminum Wire:** The ACSR conductors shall be classified as Class A as designated in ASTM B232.
3. **Steel Core:** The steel core shall consist of wires which meet the following requirements.
 - a. **Material:** The steel wire shall be fabricated from steel obtained by the open-hearth, electric furnace.
 - b. **Testing:** The steel wires shall be tested in accordance with Section 5, 6 and 10 of ASTM B498.
 - c. **Corrosion Protection:** The steel wire shall be coated with zinc to Class A requirements with coating weight described in Table 4 of ASTM B498 (2). Additional protection for ACSR conductor against corrosion of the steel core shall be provided by use of a suitable corrosion inhibition, grease or oil.
 - d. **Aluminum Wires**
 1. **Materials :** The round aluminum wires shall be drawn from rods that conform to the chemical requirements of Table 2, ASTM B230 (3)

2. **Testing:** The aluminum wire shall have tensile strengths depending on temper as shown in Table 1 of ASTM B233 (4).
3. **Resistivity:** The electrical resistivity limits and values of the aluminum rods are presented in Table 4 of ASTM B230 (3).
4. **General:** Aluminum wires are used shall meet the requirements of ASTM B230 (3)
- e. **Construction:** The number and diameter of aluminum and steel wires and the stranding shall conform to the requirements of Table 1, 2 and 3 of ASTM B232 (1).
- f. **Conductor Strength:** The rated strength shall be the aggregate strength of the steel and aluminum wires determined by the methods described in Section 9.1 of ASTM (1).
- g. **Weight and Electrical Resistance:** The weight and electrical resistance of the stranded conductor shall be determined by the methods described in Section 11 of ASTM B232 (1).

4. Insulation Jacket

Thickness of cables are:

Conductor Size AWG 2/0

Insulation Thickness (mils.) 60

PERFORMANCE REQUIREMENT: The cable shall be tested to demonstrate compliance with the requirements of Section 6 of ICEA S-66-524 (NEMA WC7, (14), in so far as applicable.

PACKAGING AND SHIPPING: Conductor shall be shipped in a non-returnable reels manufactured from “aluminum steel” or export quality preservative treated wood lagging. Wood reels and all lagging shall be constructed from new lumber which shall be square sawn, be of smooth surface, with not splits, warps, crooks, loose fibers, decay or insect infestation. The lumber used for wood reels and all lagging shall be preservative treated in accordance with “American Wood Preserves Association Standards”.

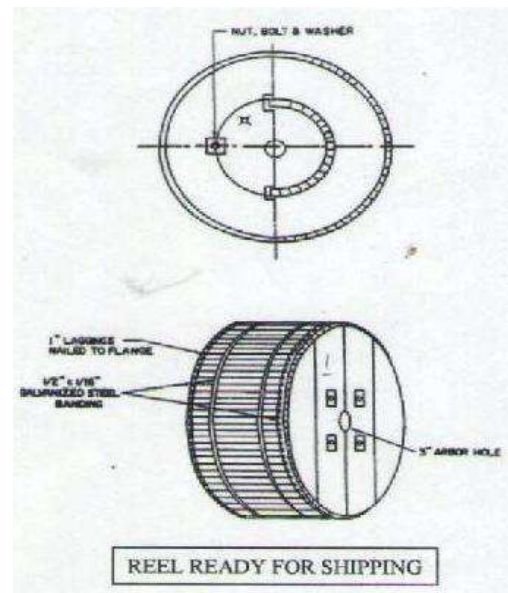

CONNECTOR, COMPRESSION (YHO 125, #6-#1/0 ACSR RUN TO #6-#2; YHD 300, #1/0-#2/0 ACSR RUN TO #1/0-#2/0)

Wide range, universal and reversible figure H shaped aluminum connector. Conductors are separated by the shape of the connector. Bendable tabs secure both run and tap conductors freeing the linemans hands to work with the installation tool. Massive aluminum design minimizes corrosion due to galvanic corrosion.



HANDTOOL OR HYDRAULIC 7 CONNECTOR PROGRAM										
CONDUCTORS (SEE BELOW FOR COMPACT CONDUCTORS)								DIMENSIONS		
GROOVE A (RUN)				GROOVE B (TAP)				H	L	W
WIRE DIAMETER RANGE	SOL.	STR.	ACSR	WIRE DIAMETER RANGE	SOL.	STR.	ACSR			
.162-.332	#6-#1	#6-#1; 7 Str.	#6-#2	.162-.332	#6-#1	#6-#1; 7 Str.	#6-#2	1.12	1.50	.70
.260-.419	#1-2/0	#3.5 Str.-2/0	#3-1/0	.162-.332	#6-1/0	#6-#1; 19 Str.	#6-#2	1.12	1.75	.70
.398-.470	3/0-4/0	2/0-3/0	1/0-2/0	.162-.332	#6-1/0	#6-#1; 19 Str.	#6-#2	1.44	1.88	.89
.475-.563	250-300	4/0	3/0-4/0	.162-.332	#6-1/0	#6-#1; 19 Str.	#6-#2	1.47	1.88	.89
.336-.470	2/0-4/0	#1, 3 Str.-3/0	#1-2/0	.336-.477	2/0-3/0	#1, 3 Str.-2/0	#1-2/0	1.42	1.88	.89
.461-.563	250-300	3/0-4/0	3/0-4/0	.338-.447	2/0-3/0	#1, 3 Str.-2/0	#1-2/0	1.42	2.50	.89
.461-.563	250-200	3/0-4/0	3/0-4/0	.461-.563	250-300	3/0-4/0	3/0-4/0	1.49	2.50	.89

COMPACT CONDUCTORS						DIMENSIONS		
GROOVE A (RUN)			GROOVE B (TAP)			H	L	W
WIRE DIAMETER RANGE	COMPACT ACSR	COMPACT CU or AL	WIRE DIAMETER RANGE	COMPACT ACSR	COMPACT CU or AL			
.162-.336	#6-#3	#6-#1	.162-.268	#6-#3	#6-#1	1.12	1.50	.70
.260-.414	#2-1/0	#2-2/0	.162-.332	#6-#1	#6-#1	1.12	1.75	.70
.398-.470	2/0-3/0	3/0	.162-.332	#6-#1	#6-#1	1.44	1.88	.89
.475-.563	4/0-266 (18/1)	4/0-266	.162-.332	#6-#1	#6-#1	1.47	1.88	.89
.336-.470	1/0-3/0	1/0-3/0	.338-.477	1/0-2/0	1/0-3/0	1.42	1.88	.89
.461-.563	3/0-266 (18/1)	4/0-266	.338-.447	1/0-2/0	1/0-3/0	1.42	2.50	.89
.461-.563	3/0-266 (18/1)	4/0-266	.461-.563	3/0-266 (18/1)	4/0-266	1.49	2.50	.89

PIN, CROSSARM, STEEL, 5/8" X 10-3/4"

The forged design of low voltage insulator pins includes flats for wrench engagement and a wide base to distribute load stresses. Each pin should come with assembled hardware. Hardware includes Square Washer, Square Nut and M-F Lock.



CUTOUT AND ARRESTER COMBINATION

GENERAL: Arrester shall protect pole-mounted equipment from voltage impulses or surges resulting from lightning strokes, system faults, circuit switching, load rejection or other events. The arresters shall limit such over voltage levels below equipment BIL ratings.

SERVICE CONDITIONS: Arresters shall meet the following physical and system conditions:

1. Ambient temperature above 40°C
2. Altitude up to 1,800 meter above sea level
3. Nominal system frequency 60 Hertz
4. Arresters shall be rated 9/10 kV MCOV, for phase to ground connection on a 13.2/7.62 kV grd Y system.

CONSTRUCTION: Arrester shall be gapless type, described briefly as follows:

Gapless arresters shall have valve elements fabricated from non-linear resistance metal oxide materials to perform both the surge discharge and power frequency reseal functions.

CONNECTORS: Both line-lead and isolator terminals shall accommodate #6 solid through 2/0 AWG stranded copper or aluminum conductors.

PROTECTIVE CHARACTERISTICS: Arresters shall have protective characteristic based on standard rms data cycle voltage summarized from ANSI C62.11 (1).



NAMEPLATE: Information required for identification must be embossed on a nameplate firmly fixed to the arrester and shall include:

- a. Arrester classification;
- b. Manufacturer's identification or symbol;
- c. Arrester model and identification number;
- d. Arrester voltage rating;
- e. Date of Manufacture

The nameplate must be eligible over the lifetime of the arrester.

MOUNTING: Distribution arrester shall be supplied with a cross arm mounting bracket that conforms the requirement of NEMA Pub. No. 1 PH25, (3), or with appropriate bracket when supplied as a cutout-arrester combination in it.

All mounting bolts and conductor connections require lock washers. Lock washer shall be fabricated from material that complies with the requirements of ANSI B18.21.1 (5).

PACKAGING: Arrester shall be securely packaged for shipping. Each package shall be clearly marked with the manufacturer's name and catalog number.

INSULATORS (PIN TYPE, SPOOL, SUSPENSION)

The pin type insulator is used in 15kV overhead distribution lines with bare or covered conductors. The insulator should meet the electrical, mechanical and environmental parameters typical of overhead distribution lines.

PIN TYPE, 15kV



SPOOL INSULATORS

Spool Insulators are used to insulate and support primary neutral and secondary (bare or covered) conductors at the pole or house using various clevis mounting configurations. Spool insulators are used with spool bolts (upset bolts) clevises, secondary racks and various brackets for dead ending or supporting secondary voltage conductors.

SPOOL INSULATOR 1 3/4"



SPOOL INSULATOR 3"

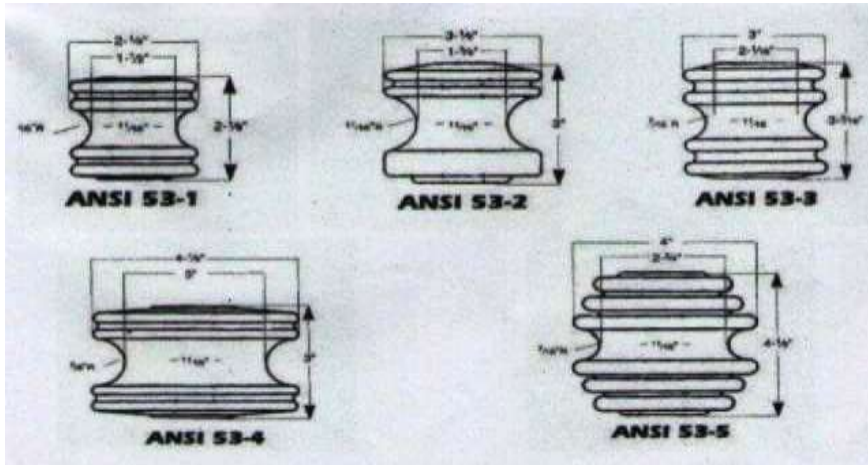

ANSI Class	53-1	53-2	53-3	53-4	53-5
Mechanical Values					
Transverse Strength (lbs.)	2,000	3,000	4,000	4,500	6,000
Electrical Values					
Low Frequency Dry Flashover (kV)	20	25	25	25	35
Low Frequency Wet Flashover, Vertical (kV)	8	12	12	12	18
Low Frequency Wet Flashover, Horizontal (kV)	10	15	15	15	25

INSULATOR, SUSPENSION, 15kV



SPECIFICATIONS: Caps are ferrous, hot-dip galvanized. Suspensions should be available for ball-socket or clevis eye insulator coupling. Caps are cemented on the porcelain. Suspensions should be made from flint-body porcelain or high strength alumina-body porcelain. Assembled units should be subjected to rigorous electrical and mechanical tests before shipment. The porcelain shell or shed should be designed to provide optimum leakage distance in relation to the shell diameter. The sturdy shed design also protects the leakage corrugations from mechanical damage.

GROUNDING

GROUNDING

ROD

Made of high carbon steel for maximum strength. Hot Dip Galvanized.
Does not bend when driven into hard soils.

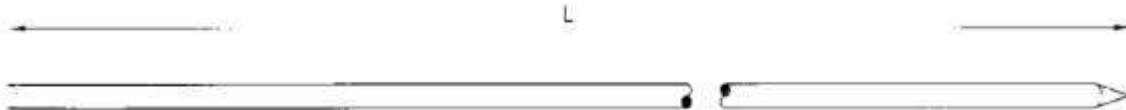

1/2"					
L FEET	STANDARD UNIT WEIGHT (PIECE) (KG)	STANDARD PIECES PER BOX/BUNDLE	CATALOG NUMBER		
			JFI	MACLEAN	HUBBELL
5	1.37	10	JF5315	J5315	8565
6	1.64	10	JF5316	J5316	8566
10	2.73	10	JF5317	J5317	

5/8"					
L FEET	STANDARD UNIT WEIGHT (PIECE) (KG)	STANDARD PIECES PER BOX/BUNDLE	CATALOG NUMBER		
			JFI	MACLEAN	HUBBELL
4	1.70	10	JF5324	J5324	
5	2.14	10	JF5325	J5325	
6	2.3	5	JF5326	J5326	8576
8	3.41	5	JF5328	J5328	8578
10	4.25	5	JF5330	J5330	8580

3/4"					
L FEET	STANDARD UNIT WEIGHT (PIECE) (KG)	STANDARD PIECES PER BOX/BUNDLE	CATALOG NUMBER		
			JFI	MACLEAN	HUBBELL
10	5.72	5	JF5340	J5340	8620

ANCHOR RODS

ANCHOR RODS

Available for one or two guys for use with expanding and cross-plate anchors. Thimble Eye, Twin Eye and Triple Eye rods distribute pulling stresses uniformly over individual strands of guy wire and keep the guy wire from spreading, kinking, or bending. The drop-forged eye of each anchor rod is stronger than the rod itself. Each rod is threaded 6", Nuts included.

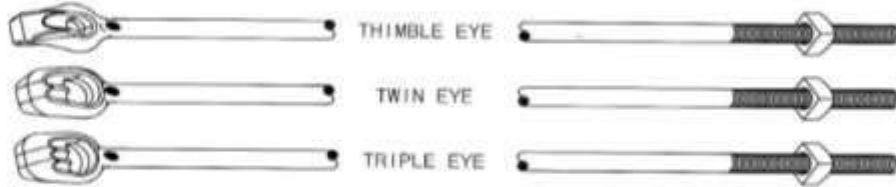

THIMBLE EYE						
5/8"						
LENGTH FEET	THREAD LENGTH MM	STANDARD UNIT WEIGHT(PC)(KG)	STANDARD PIECES PER BOX/BUNDLE	DRAWING NUMBER		
6	150	2.57	5	JF1	MACLEAN	HUBBELL
7		3.10		JF7416	J7416	T-5316
8		3.38		JF7417	J7417	T-5317
				JF7418	J7418	T-5318
3/4"						
LENGTH FEET	THREAD LENGTH MM	STANDARD UNIT WEIGHT(PC)(KG)	STANDARD PIECES PER BOX/BUNDLE	DRAWING NUMBER		
7	150	4.41	5	JF1	MACLEAN	HUBBELL
8		5.06		JF7427	J7427	+5327
10		6.10		JF7428	J7428	T-5328
				JF7430	J7430	
TWIN EYE						
5/8"						
LENGTH FEET	THREAD LENGTH MM	STANDARD UNIT WEIGHT(PC)(KG)	STANDARD PIECES PER BOX/BUNDLE	DRAWING NUMBER		
6	150	2.57	5	JF1	MACLEAN	HUBBELL
7		3.10		JF7516	J7516	5346
8		3.38		JF7517	J7517	T-5317
				JF7518	J7518	T-5318
3/4"						
LENGTH FEET	THREAD LENGTH MM	STANDARD UNIT WEIGHT(PC)(KG)	STANDARD PIECES PER BOX/BUNDLE	DRAWING NUMBER		
7	150	4.42	5	JF1	MACLEAN	HUBBELL
8		5.06		JF7527	J7527	+5357
10		6.55		JF7528	J7528	T-5358
				JF7530	J7530	T-5360
1"						
LENGTH FEET	THREAD LENGTH MM	STANDARD UNIT WEIGHT(PC)(KG)	STANDARD PIECES PER BOX/BUNDLE	DRAWING NUMBER		
8	150	6.77	5	JF1	MACLEAN	HUBBELL
10		7.40		JF7538	J7538	+5368
				JF7540	J7540	T-5370
TRIPLE EYE						
3/4"						
LENGTH FEET	THREAD LENGTH MM	STANDARD UNIT WEIGHT(PC)(KG)	STANDARD PIECES PER BOX/BUNDLE	DRAWING NUMBER		
6	150	4.11	5	JF1	MACLEAN	HUBBELL
7		4.76		JF7326	J7327	C2000099
8		5.30		JF7327	J7328	C2000098
9		6.08		JF7328	J7329	C2000097
10		6.70		JF7329	J7330	

WASHERS

SQUARE FLAT



STOCK (INCHES)	HOLE DIA. (MM)	BOLT DIA. (INCHES)	STANDARD UNIT WEIGHT (PIECE)(KG)	STANDARD PIECES PER BOX / BUNDLE	CATALOG NO.				
					JFI	MACLEAN	HUBBELL		
2 x 2 x 1 / 8	14	1/2	0.06	250	JF1073-01	J1073	6811		
2 x 2 x 1 / 8			JF1073-01		J1074	6812			
2 x 2 x 3 / 16			0.09	200	JF1074-01				
2 1/4 x 2-1/4 x 3 / 16			0.12		JF1075-01	J1075	6813		
2-1/2 x 2-1/2 x 3 / 16			0.10		JF1076-01				
3 x 3 x 3 / 16			18	5/8	0.18	150	JF1078-01		
3 x 3 x 1 / 4					0.26		JF1079-01		
4 x 4 x 3 / 16					0.34	JF1080-01			
4 x 4 x 1 / 4					0.48	10	JF1082-01		
4 x 4 x 1 / 2					0.90		JF1081-01		
2 x 2 x 3 / 16	0.09	200			JF1074-02				
2-1/4 x 2-1/4 x 3 / 16	0.12				JF1075-02	J1075	6814		
2-1/2 x 2-1/2 x 3 / 16	0.095				JF1076-02				
3 x 3 x 3 / 16	21	3/4	0.17	150	JF1078-02	J1078	6816		
3 x 3 x 1 / 4			0.25		JF1079-02	J1079	6817		
4 x 4 x 3 / 16			0.34	120	JF1080-02	J1080	6818		
4 x 4 x 1 / 4			0.47		10	JF1082-02	J1082	681812	
4 x 4 x 1 / 2			0.90			JF1081-02		681912	
4 x 4 x 1 / 4			24	7/8	1.23	JF1082-03	J1082	6918	

PIN, INSULATOR POLE TOP

**Available with Nylon or Lead Threads
for 1" or 1-3/8" Diameter Insulator Threads**

Used for supporting pin type insulators in pole top installation.

FEATURES:

- Pins can be mounted with flange facing against or away from pole
- Lower mounting hole is slotted for bolt alignment

Advantages of Nylon Threads

- Eliminate worker handling and environmental disposal concerns associated with lead threads
- Firm and resilient fit, resulting in improved insulator installation
- Facilitates insulator groove alignment
- Compliance with ANSI performance and dimensional specifications



MATERIAL:

- Semi-conductive nylon or lead threads
- Pressed steel body is galvanized per ASTM A-153

RODS, GROUND, GALVANIZED



Ground Rods are available with or without copper wire. Made of high-carbon, open-hearth steel for maximum strength. Hot dip galvanized. Does not bend when driven into hard soils. The electro-brazed pigtail is No. 6 tinned copper on 5/8" and 3/4" rod. Bolt-Type Drive Head Ground Rods have surfaces of head and integral clamp tinned. Hot dip galvanized steel rod. Non-ferrous bolt with lock washer accommodates No. 3 to No. 8 stranded wire.

NUT, EYE 5/8” CONVENTIONAL

5/8” bolt size, 11 thread per inch

Eye nuts are tapped to fit hot dip galvanized bolts made to ANSI Specifications and are designed to develop strength ratings consistent with the bolts with which they are used. Eye nuts are used for span, head and stub guying.



XXVII. NUT, LOCK, M-F TYPE, 5/8”



Concave locknuts are designed to spin freely by hand. When tightened down over an existing nut, the arch is flattened causing a permanent set

PIN, POLE TOP, CHANNEL 1" THREAD, 20" LONG

Insulator thread 1" ANSI and the overall length is 20" and the hole spacing is 8".

Pole Top Insulator Pin 20" long with 1" lead threads. Straight base design with two mounting holes. Hot dip galvanized pressed steel. Note: actual part does not include upper most hole.



ROD, ANCHOR, THREADED, SINGLE EYE, 5/8" X 7'



Used for guying utility post

ROD, GROUND STEEL, GALVANIZED, 5/8" X 10'



A ground rod or a ground field's only purpose in life is to have a designed electrical path to dissipate a static discharge voltage (such as Lightning) to earth.

If you place a current probe around the conductor going to earth or the ground rod itself you should never see any current flowing on the conductor. If current is seen flowing on the conductor going to earth a ground fault exists. Another term that could be used is leakage current. In either case there is a parallel path back to the voltage source through the earth that crates the loop for current to flow on the earth ground conductor.

SPACER, PIPE, 3/4" X 1-1/2"



Spacers play an important and practical role in lined piping systems. Some of the many uses for spacers are:

- Making up for gaps between lined materials that are too short for a standard pipe spool or a distance piece.
- Allowing butterfly valves to fully open in lined piping systems.
- Protecting the lined pipe flare from damage when bolting up to unlined flanges.

- Tapered spacers provide drainage or correct misalignments in lined piping systems
- Allowing lined pipe flanges (raised face) to bolt to FRP flanges (flat face)

STEEL POLES

SCOPE: This specification establishes the physical characteristics and performance requirements of steel poles for use in Camarines Norte Electric Cooperative, Inc. electric distribution system. Poles furnished to NEA specifications shall conform in all respects to the performance of this standard. The text, figures and references of other standards supplement each other and shall be considered part of this standard. The poles are to be of the embedded type and not to require a special foundation.

MATERIAL: Steel poles shall be fabricated from structural quality hot rolled steel which conforms to ASTM A570-79, ‘Standard Specifications for Hot-Rolled Carbon Steel Sheet and Strip, Structural Quality.’

FINISHING: The pole shall be cleaned of scale, rust, oil, paint and other surface contaminants and then rinsed in an alkaline cleaning bath. The steel shall then be bathed in a diluted acid (sulfuric or hydrochloric) bath for at least five minutes. Just prior to galvanizing, the acid cleaned steel shall be immersed in a flux solution of 30% zinc ammonium chloride with wetting agents and maintained at 65°C until galvanizing is completed. Steel poles shall be hot dip galvanized in accordance with ANSVASTM A153-82, Standard Specification for Zinc Coating (Hot Dip) on Iron and Steel Hardware. This standard requires a minimum zinc coating of 610 grams/sq. m. The coating shall be continuous, smooth, reasonably uniform in thickness and free of blemishes and other imperfections which are inconsistent with commercial practice. Galvanized articles shall be free from coated areas, blisters, flux deposits, acid and black spots and dross inclusions. Lumps, projections, globules or heavy deposits of zinc which will interfere with the intended use of the material will not be permitted. All holes shall be clean and reasonably free from excess zinc.

DIMENSION AND STRENGTH: The poles are specified in accordance with the National Electrification Administration’s (NEA) issued Memorandum No. 2007-007 dated February 15, 2007 on the NEA/EC Specifications for Steel Poles.

MARKINGS: Each steel pole shall be identified by the Supplier by stamping into the pole, prior to coating, with letters not less than ½” high squarely on the face of the pole at ten (10) feet from the butt of the pole. The following shall be stamped into the pole:

- Supplier’s Name;
- Month and Year of Manufacture;
- Length of Pole;
- Class of Pole;
- Type of Coating;
- Pole Production or Serial Number

The marks shall be legible after application of the protective coating.

INSPECTION AND TESTING: The manufacturer shall conduct factory tests to verify that the poles comply with the requirements of this standard. CANORECO reserves the right to witness

ANY OR ALL factory tests and the supplier shall notify CANORECO fifteen (15) days before each test is to be conducted. The Supplier is required to furnish CANORECO a copy of all the test reports.

TESTING: One pole out of every lot of 25 poles shall be tested and should pass the following tests;

- Proof Load Test; and
- Break Load Test

REPORT:

For tests conducted at source, the test shall be prepared by the manufacturer in coordination with the witnessing inspection engineer or test engineer.

The following test data shall be collected and recorded in accordance with the attached format:

- Manufacturer’s Serial Number of the Test Pole Sample;
- Pole Class;
- Date Manufactured;
- Date Tested;
- Pole Dimensions;
- Load, Including Point of Failure;
- Deflection; and
- Recovery

Height (ft.)	Thickness (mm)	Butt Diameter (mm)	Tip Diameter (mm)	Design Load (kg.)	Yield Stress (MPA)	Zinc Coating (microns)
25	3.00	152	120	300	345	86
30	3.00	226	127	500	345	86
35	3.00	248	127	500	345	86
40	3.00	317	127	500	345	86

*Pole, Steel, 45’ Bare-4.0mm (Two Section),86 micron,750 kgs (min. load break)

*Pole, Steel, 55’ Bare-4.0mm (Two Section),86 micron,1200 kgs (min. load break)

*Pole, Steel, 60’ Bare-4.0mm (Two Section),86 micron,1200 kgs (min. load break)

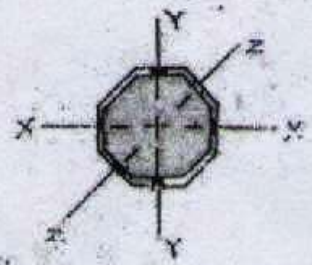
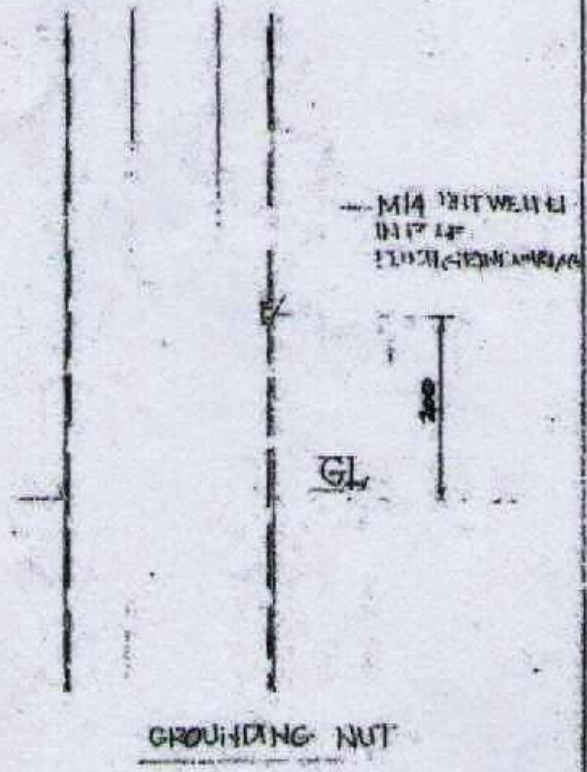
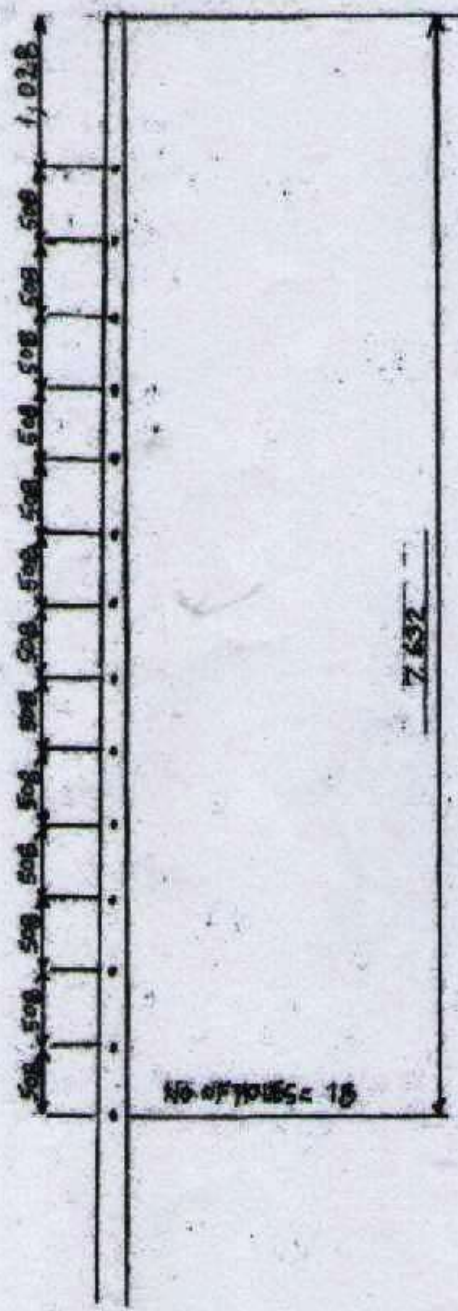

- NOTE:
1. ALL HOLES ARE 1/8" DIA. UNLESS OTHERWISE SPECIFIED.
 2. ALL HOLES ARE THROUGH TO THE PILE BODY.
 3. ANY BURRS THAT REMAIN SHOULD BE REMOVED.
 4. ALL THREADS MUST BE HAND-TAPPED WITH 60° STANDARD TAPER.

NATIONAL
ELECTRIFICATION
ADMINISTRATION

SEE IN DETENTION FILE
FOR ALL
SHEET HOLES AND GROUNDING TAP.

SHEET 2/4

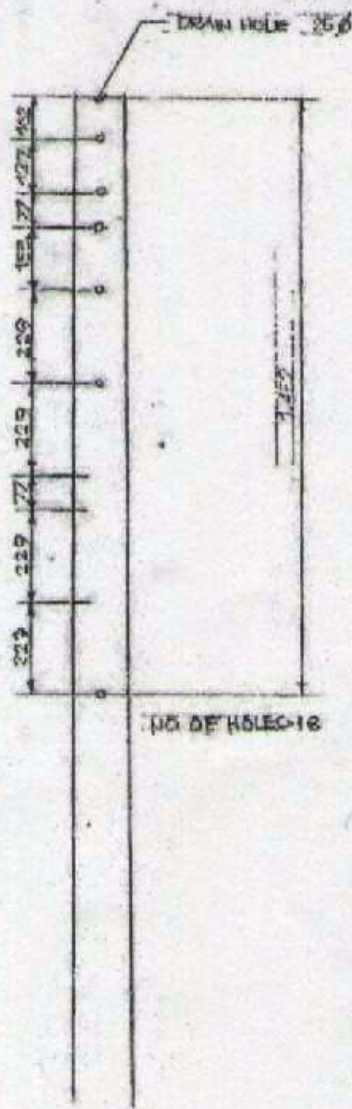

PLANE X-X

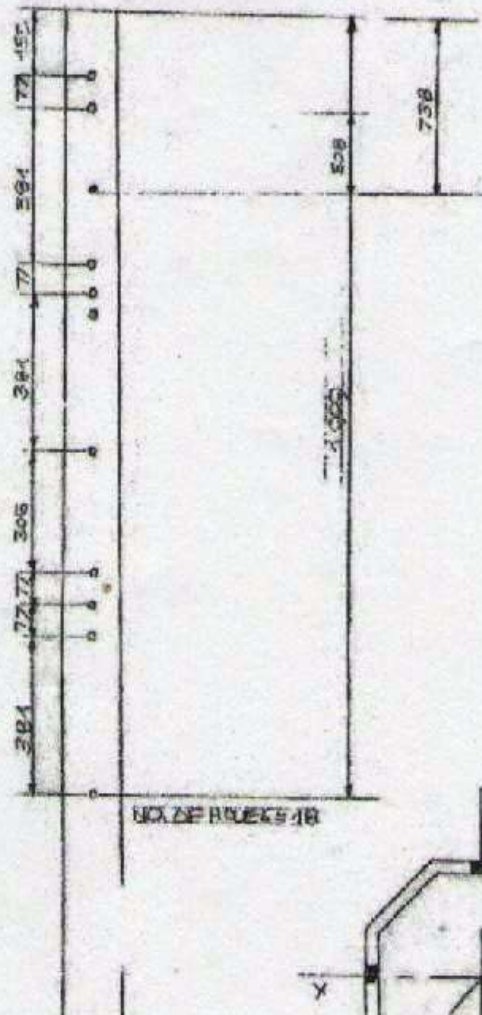

PLANE Y-Y

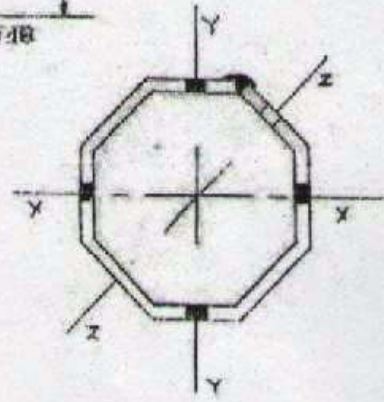

HOLE PLANES

- NOTES:
1. ALL HOLES ARE 10 MINUS UNLESS OTHERWISE SPECIFIED
 2. ALL HOLES ARE THROUGH AND THROUGH TO THE BASE BODY
 3. ANY BURRS THAT REMAIN SHOULD BE REMOVED.

NATIONAL
ELECTRIFICATION
ADMINISTRATION

35 FT DISTRIBUTION POLE
OCTAGONAL
FRAMING HOLES DETAIL

SHEET 2/4

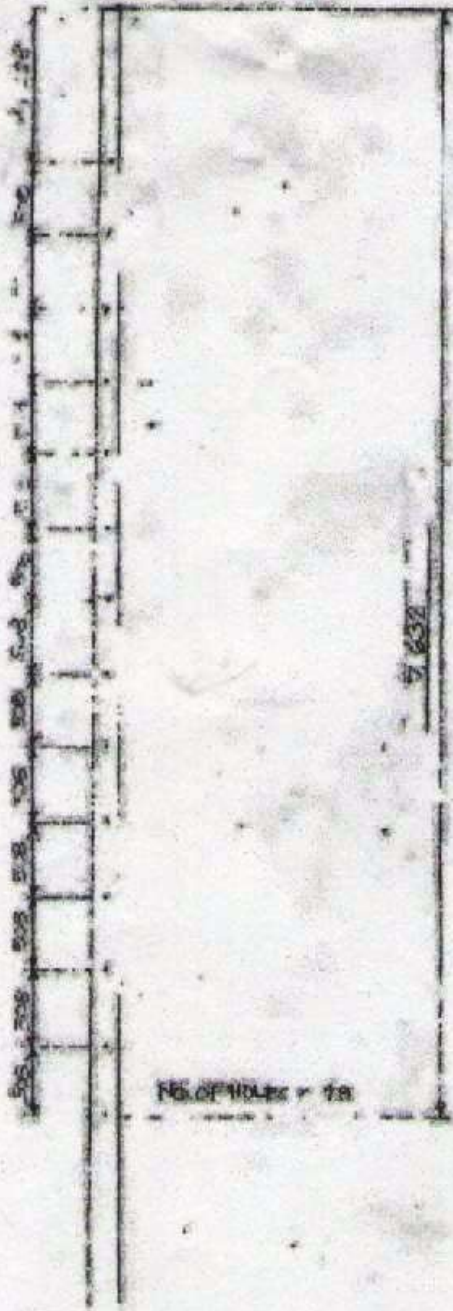

PLANE Z-Z

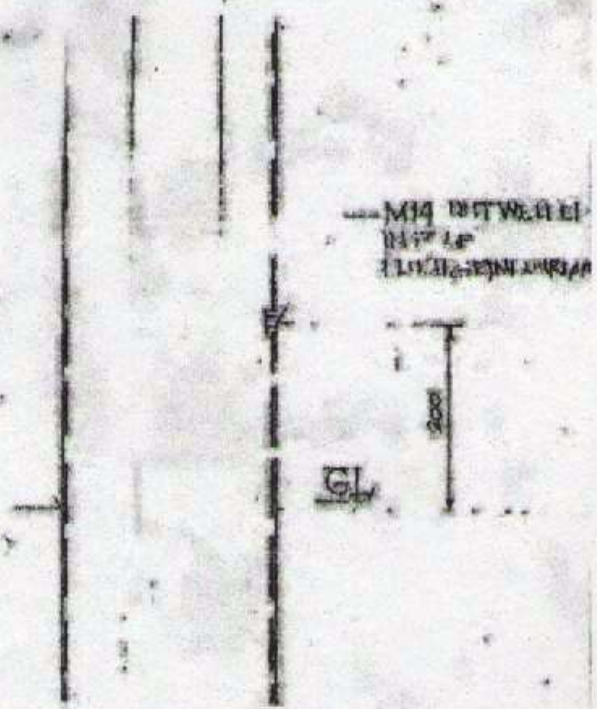

GROUNDING NUT

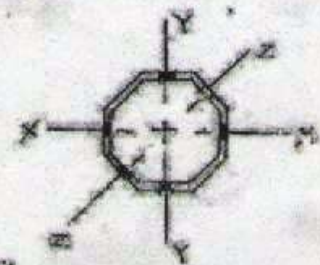

- NOTE:
1. ALL HOLES ARE DRILLED DIRECT OVER THE CENTER OF THE HOLE.
 2. ALL HOLES ARE THROUGH TO THE FULL BODY.
 3. ANY BURR THAT REMAINS SHOULD BE REMOVED.
 4. ALL SURFACES MUST BE HAND POLISHED AFTER DRILLING.

NATIONAL
ELECTRIFICATION
ADMINISTRATION

SEE INSTRUCTION BOOK
FOR DETAILS
OF HOLES AND CONNECTIONS

SHEET 24A

DRAIN HOLES 25φ

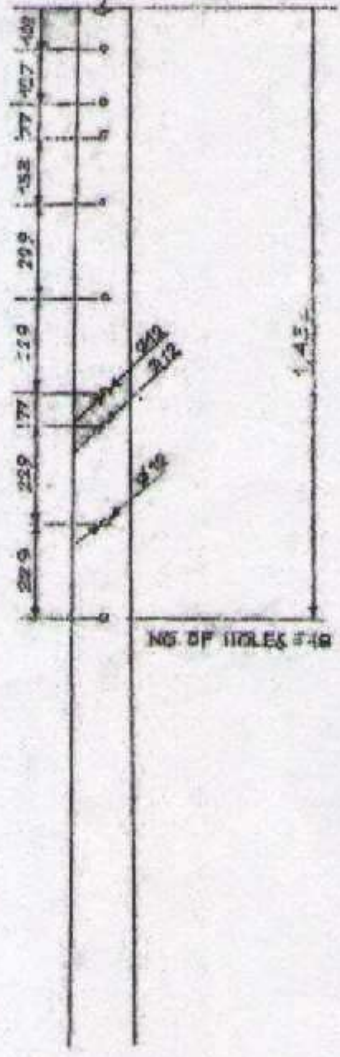

PLANE X-X

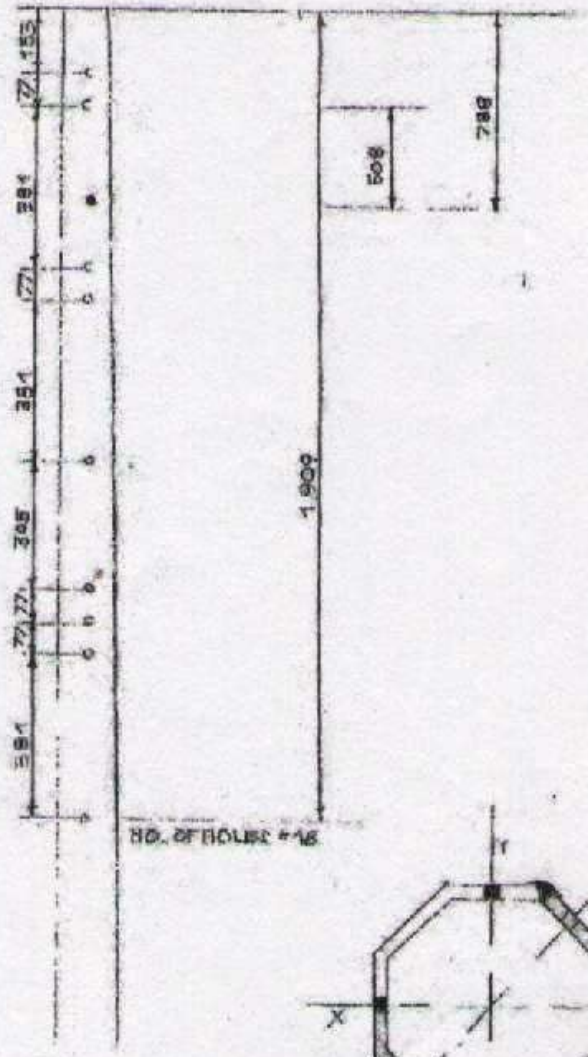

PLANE Y-Y

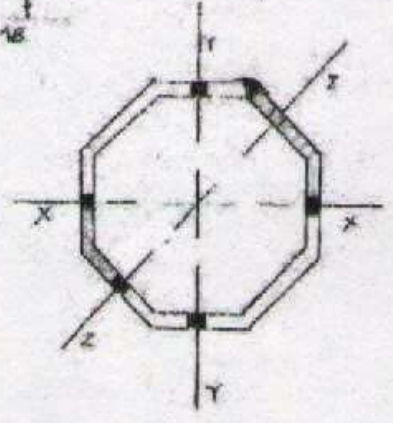

POLE PLANES

NOTES:

1. ALL HOLES ARE TO FIT UNLESS OTHERWISE SPECIFIED
2. ALL HOLES ARE THROUGH AND THROUGH TO THE POLE BODY
3. ANY BURRS THAT REMAIN SHOULD BE REMOVED

NATIONAL
ELECTRIFICATION
ADMINISTRATION

35PT DISTRIBUTION POLE
OCTAGONAL
FRAMING HOLES DETAIL

1/11/81

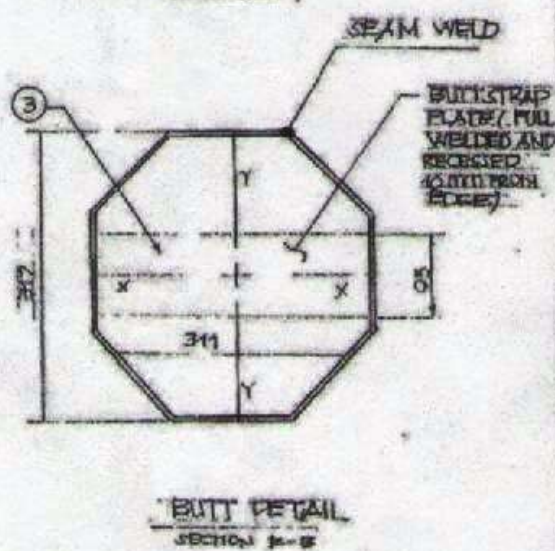
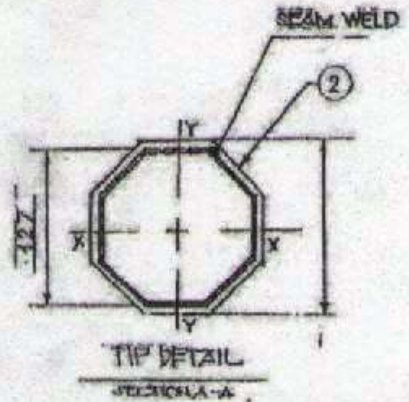
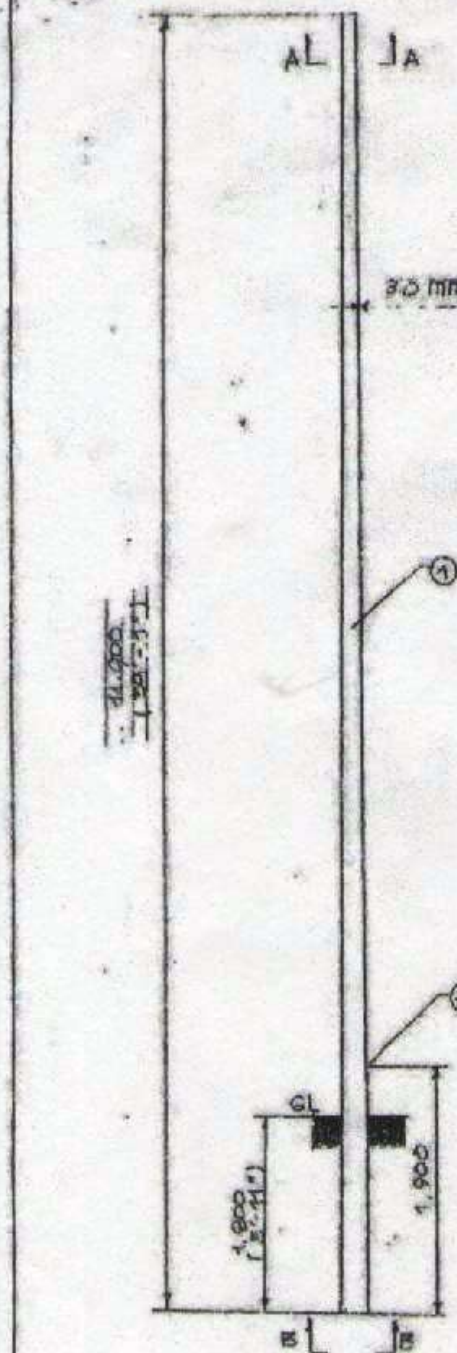

- NOTES:**
1. ALL DIMENSIONS ARE IN MM UNLESS SPECIFIED
 2. ALL STEEL PLATES SHALL CONFORM TO ASTM A36 WITH 510 MPa YIELD STRENGTH
 3. ALL WELDING SHALL BE DONE IN ACCORDANCE WITH AWS D1.1
 4. ALL STEEL SHALL BE HOT DIP GALVANIZED IN ACCORDANCE WITH ASTM A123

NOTATION:
 ALL STEEL PLATES SHALL CONFORM TO ASTM A36 WITH 350 MPa MIN. YIELD STRENGTH INSTEAD OF 310 MPa YIELD STRENGTH

NATIONAL
 ELECTRIFICATION
 ADMINISTRATION

40FT. DISTRIBUTION POLE
 OCTAGONAL
 GENERAL ARRANGEMENT DRAWING

DEE/yz

CROSSARM STEEL 8' or 10'



Brace Crossarm Steel Angle 60



TIE WIRE



Section VIII. Bidding Forms

Item Number	Description	Quantity	Total	Statement of Compliance (Comply or Not Comply)
1	Attachment Guy Malleable Iron	pcs	233	
2	Bolt Carriage 3/8" x 4-1/2"	pcs	330	
3	Bolt Double Arming 5/8 x 20	pcs	9	
4	Bolt Double Arming 5/8 x 22	pcs	226	
5	Bolt Double Arming 5/8 x 24	pcs	161	
6	Bolt Double Arming 5/8 x 26	pcs	6	
7	Bolt Double Upset 5/8 x 10	pcs	29	
8	Bolt Eye Oval 5/8 x 9	pcs	60	
9	Bolt Eye Oval 5/8 x 10	pcs	182	
10	Bolt Eye Oval 5/8 x 12	pcs	420	
11	Bolt Eye Oval 5/8 x 18	pcs	204	
12	Machine Bolt 1/2 x 8	pcs	2	
13	Machine Bolt 1/2 x 10	pcs	631	
14	Machine Bolt 1/2 x 12	pcs	124	
15	Machine Bolt 5/8 x 8	pcs	159	
16	Machine Bolt 5/8 x 10	pcs	551	
17	Machine Bolt 5/8 x 12	pcs	60	
18	Machine Bolt 5/8 x 14	pcs	85	
19	Machine Bolt 5/8 x 16	pcs	540	
20	Bolt Single Upset 5/8 x 8	pcs	3	
21	Bolt Single Upset 5/8 x 10	pcs	38	
22	Bolt Single Upset 5/8 x 12	pcs	4	
23	Brace Crossarm Steel 28 Span	pcs	330	
24	Brace Crossarm Steel Angle Steel	pcs	62	
25	Brace Sidearm Vertical	pcs	328	
26	Brace Sidearm Diagonal, 7 ft.	pcs	328	
27	Bracket Clevis Deadend w/o Spool	pcs	312	
28	Connector Hotline Clamp 2-4/0	pcs	166	
29	Clamp Anchor Rod Bonding Single Eye	pcs	97	
30	Clamp Loop Deadend #6 2/0 ACSR	pcs	676	
31	Clamp Cond Deadend Strain 4-4/0	pcs	483	
32	Clamp Guy 3 Bolt	pcs	490	
33	Clamp Suspension Alloy 2/0	pcs	52	
34	Clamp Guy Bond	pcs	136	

35	Clevis Secondary Swinging	pcs	387	
36	Shackle Anchor	pcs	271	
37	Conductor Bare ACSR #2	mtrs	15,044	
38	Conductor Bare ACSR #1/0	mtrs	48,835	
39	Conductor Bare ACSR #4/0	mtrs	100,551	
40	Conductor Duplex #2	mtrs	374	
41	Connector Compression YHO 150	pcs	921	
42	Connector Compression YHO 200	pcs	89	
43	Connector Compression YHO 300	pcs	85	
44	Connector Compression YHO 400	pcs	236	
45	Connector Ground Rod Clamp	pcs	172	
46	Pin Crossarm Long Shunk	pcs	1,514	
47	Fuse Cutout & Arrester Comb.	set	76	
48	Guy Hook	pcs	20	
49	Insulator Pin Type 55-5	pcs	1,665	
50	Insulator Spool 1 3/4	pcs	153	
51	Insulator Spool 3	pcs	620	
52	Insulator Suspension	pcs	1,114	
53	Nut Eye Conventional 5/8	pcs	510	
54	Nut Lock 3/8	pcs	330	
55	Nut Lock 1/2	pcs	1,210	
56	Nut lock 5/8	pcs	3,649	
57	Pin Pole Top	pcs	118	
58	Rod Anchor Threaded Single Eye	pcs	197	
59	Rod Ground Steel 5/8 x 10	pcs	172	
60	Lug terminal #2	pcs	260	
61	Spacer Pipe	pcs	52	
62	Washer Square Flat 2 1/4 x 2 1/4	pcs	3,902	
63	Washer Square Flat 4 x 4	pcs	197	
64	Washer Round	pcs	1,210	
65	Tie Wire	ft	15,352	
66	Aarmor Tape 05 x .30	ft	439	
67	Ground Wire Alum. Alloy #4-3 Strand	ft	8,158	
68	Guy Wire	ft	12,380	
69	Steel Pole 30ft	pcs	25	
70	Steel Pole 40ft	pcs	414	
71	Steel Pole 45ft	pcs	111	

72	Steel Pole 50ft	pcs	14	
73	Anchor Log	pcs	197	
74	Crossarm Steel 8ft	pcs	928	
75	Crossarm Steel 10ft	pcs	22	
76	Insulator Post Type, Porcelain w/7 Stud	pcs	2	
77	Clamp, Suspension, Alum Alloy Clevis 2 bolts	pcs	15	
78	Clamp Groud Wire, Deadend Strain Clevis	pcs	2	
79	Truss Guy Down Guy	pcs	2	

NOTE: Please indicate the following vital details of your proposal;

BRAND : _____

AVAILABILITY : _____

VALIDITY : _____

DELIVERY : _____

WARRANTY : _____

TERMS OF PAYMENT : _____

Submitted By:

Name and Signature: _____

Position : _____

Company : _____

Date : _____

TABLE OF CONTENTS

BID FORM	110
CONTRACT AGREEMENT FORM	113
OMNIBUS SWORN STATEMENT	115
BANK GUARENTEE FORM FOR ADVANCE PAYMENT	118
BID SECURING DECLARATION FORM	119

Bid Form

Date: November 09, 2020
Invitation to Bid¹ N^o:2020-075

To: ***Bids and Awards Committee (BAC)***
Camarines Norte Electric Cooperative, Inc. (CANORECO)
Jose P. Rizal Street, Barangay I, Daet, Camarines Norte

Gentlemen and/or Ladies:

Having examined the Bidding Documents including Bid Bulletin Numbers _____, the receipt of which is hereby duly acknowledged, we, the undersigned, offer to *supply various warehouse materials* in conformity with the said Bidding Documents for the sum of _____ or such other sums as may be ascertained in accordance with the Schedule of Prices attached herewith and made part of this Bid.

We undertake, if our Bid is accepted, to deliver the goods in accordance with the delivery schedule specified in the Schedule of Requirements.

If our Bid is accepted, we undertake to provide a performance security in the form, amounts, and within the times specified in the Bidding Documents.

We agree to abide by this Bid for the Bid Validity Period specified in **BDS** provision for **ITB** Clause 18.2 and it shall remain binding upon us and may be accepted at any time before the expiration of that period.

Commissions or gratuities, if any, paid or to be paid by us to agents relating to this Bid, and to contract execution if we are awarded the contract, are listed below:²

Name and address of agent	Amount and Currency	Purpose of Commission or gratuity
_____	_____	_____
_____	_____	_____
_____	_____	_____

(if none, state "None")

Until a formal Contract is prepared and executed, this Bid, together with your written acceptance thereof and your Notice of Award, shall be binding upon us.

¹ If ADB, JICA and WB funded projects, use IFB.

² Applicable only if the Funding Source is the ADB, JICA or WB.

We understand that you are not bound to accept the Lowest Calculated Bid or any Bid you may receive.

We certify/confirm that we comply with the eligibility requirements as per **ITB** Clause 5 of the Bidding Documents.

We likewise certify/confirm that the undersigned, *[for sole proprietorships, insert: as the owner and sole proprietor or authorized representative of Name of Bidder, has the full power and authority to participate, submit the bid, and to sign and execute the ensuing contract, on the latter's behalf for the Name of Project of the Name of the Procuring Entity][for partnerships, corporations, cooperatives, or joint ventures, insert: is granted full power and authority by the Name of Bidder, to participate, submit the bid, and to sign and execute the ensuing contract on the latter's behalf for Name of Project of the Name of the Procuring Entity].*

We acknowledge that failure to sign each and every page of this Bid Form, including the attached Schedule of Prices, shall be a ground for the rejection of our bid.

Dated this 9th day of November 2020.

[signature]

[in the capacity of]

Duly authorized to sign Bid for and on behalf of _____

For Goods Offered From Abroad

Name of Bidder _____ . Invitation to Bid³ Number ____ . Page ____ of _____ .

1	2	3	4	5	6	7	8	9
Item	Description	Country of origin	Quantity	Unit price CIF port of entry (specify port) or CIP named place (specify border point or place of destination)	Total CIF or CIP price per item (col. 4 x 5)	Unit Price Delivered Duty Unpaid (DDU)	Unit price Delivered Duty Paid (DDP)	Total Price delivered DDP (col 4 x 8)

[signature]

[in the capacity of]

Duly authorized to sign Bid for and on behalf of _____

For Goods Offered From Within the Philippines

³ If ADB, JICA and WB funded projects, use IFB.

Name of Bidder _____ . Invitation to Bid⁴ Number _ . Page . of ____.

1	2	3	4	5	6	7	8	9	10
Item	Description	Country of origin	Quantity	Unit price EXWper item	Transportation and Insurance and all other costs incidental to delivery, per item	Sales and other taxes payable if Contract is awarded, per item	Cost of Incidental Services, if applicable, per item	Total Price, per unit (col 5+6+7+8)	Total Price delivered Final Destination (col 9) x (col 4)

[signature]

[in the capacity of]

Duly authorized to sign Bid for and on behalf of _____

⁴ If ADB, JICA and WB funded projects, use IFB.

Contract Agreement Form

THIS AGREEMENT made the _____ day of _____ 2020 between *Camarines Norte Electric Cooperative, Inc. (CANORECO)* of the Philippines (hereinafter called “the Entity”) of the one part and _____ of _____ (hereinafter called “the Supplier”) of the other part:

WHEREAS the Entity invited Bids for certain goods and ancillary services, viz., *various warehouse materials* and has accepted a Bid by the Supplier for the supply of those goods and services in the sum of [*contract price in words and figures*] (hereinafter called “the Contract Price”).

NOW THIS AGREEMENT WITNESSETH AS FOLLOWS:

1. In this Agreement words and expressions shall have the same meanings as are respectively assigned to them in the Conditions of Contract referred to.
2. The following documents shall be deemed to form and be read and construed as part of this Agreement, viz.:
 - (a) the Supplier’s Bid, including the Technical and Financial Proposals, and all other documents/statements submitted (*e.g.* bidder’s response to clarifications on the bid), including corrections to the bid resulting from the Procuring Entity’s bid evaluation;
 - (b) the Schedule of Requirements;
 - (c) the Technical Specifications;
 - (d) the General Conditions of Contract;
 - (e) the Special Conditions of Contract;
 - (f) the Performance Security; and
 - (g) the Entity’s Notice of Award.
3. In consideration of the payments to be made by the Entity to the Supplier as hereinafter mentioned, the Supplier hereby covenants with the Entity to provide the goods and services and to remedy defects therein in conformity in all respects with the provisions of the Contract
4. The Entity hereby covenants to pay the Supplier in consideration of the provision of the goods and services and the remedying of defects therein, the Contract Price or such other sum as may become payable under the provisions of the contract at the time and in the manner prescribed by the contract.

IN WITNESS whereof the parties hereto have caused this Agreement to be executed in accordance with the laws of the Republic of the Philippines on the day and year first above written.

Signed, sealed, delivered by _____ the _____ (for the Entity)

Signed, sealed, delivered by _____ the _____ (for the Supplier).

Omnibus Sworn Statement

REPUBLIC OF THE PHILIPPINES)
CITY/MUNICIPALITY OF _____) S.S.

AFFIDAVIT

I, *[Name of Affiant]*, of legal age, *[Civil Status]*, *[Nationality]*, and residing at *[Address of Affiant]*, after having been duly sworn in accordance with law, do hereby depose and state that:

1. **Select one, delete the other:**

If a sole proprietorship: I am the sole proprietor or authorized representative of *[Name of Bidder]* with office address at *[address of Bidder]*;

If a partnership, corporation, cooperative, or joint venture: I am the duly authorized and designated representative of *[Name of Bidder]* with office address at *[address of Bidder]*;

2. **Select one, delete the other:**

If a sole proprietorship: As the owner and sole proprietor, or authorized representative of *[Name of Bidder]*, I have full power and authority to do, execute and perform any and all acts necessary to participate, submit the bid, and to sign and execute the ensuing contract for *[Name of the Project]* of the *[Name of the Procuring Entity]*, as shown in the attached *duly notarized Special Power of Attorney*;

If a partnership, corporation, cooperative, or joint venture: I am granted full power and authority to do, execute and perform any and all acts necessary to participate, submit the bid, and to sign and execute the ensuing contract for *[Name of the Project]* of the *[Name of the Procuring Entity]*, as shown in the attached *[state title of attached document showing proof of authorization (e.g., duly notarized Secretary's Certificate, Board/Partnership Resolution, or Special Power of Attorney, whichever is applicable;)]*;

3. *[Name of Bidder]* is not "blacklisted" or barred from bidding by the Government of the Philippines or any of its agencies, offices, corporations, or Local Government Units, foreign government/foreign or international financing institution whose blacklisting rules have been recognized by the Government Procurement Policy Board;
4. Each of the documents submitted in satisfaction of the bidding requirements is an authentic copy of the original, complete, and all statements and information provided therein are true and correct;
5. *[Name of Bidder]* is authorizing the Head of the Procuring Entity or its duly authorized representative(s) to verify all the documents submitted;

6. *Select one, delete the rest:*

If a sole proprietorship: The owner or sole proprietor is not related to the Head of the Procuring Entity, members of the Bids and Awards Committee (BAC), the Technical Working Group, and the BAC Secretariat, the head of the Project Management Office or the end-user unit, and the project consultants by consanguinity or affinity up to the third civil degree;

If a partnership or cooperative: None of the officers and members of [Name of Bidder] is related to the Head of the Procuring Entity, members of the Bids and Awards Committee (BAC), the Technical Working Group, and the BAC Secretariat, the head of the Project Management Office or the end-user unit, and the project consultants by consanguinity or affinity up to the third civil degree;

If a corporation or joint venture: None of the officers, directors, and controlling stockholders of [Name of Bidder] is related to the Head of the Procuring Entity, members of the Bids and Awards Committee (BAC), the Technical Working Group, and the BAC Secretariat, the head of the Project Management Office or the end-user unit, and the project consultants by consanguinity or affinity up to the third civil degree;

7. [Name of Bidder] complies with existing labor laws and standards; and
8. [Name of Bidder] is aware of and has undertaken the following responsibilities as a Bidder:
- a) Carefully examine all of the Bidding Documents;
 - b) Acknowledge all conditions, local or otherwise, affecting the implementation of the Contract;
 - c) Made an estimate of the facilities available and needed for the contract to be bid, if any; and
 - d) Inquire or secure Supplemental/Bid Bulletin(s) issued for the [Name of the Project].
9. [Name of Bidder] did not give or pay directly or indirectly, any commission, amount, fee, or any form of consideration, pecuniary or otherwise, to any person or official, personnel or representative of the government in relation to any procurement project or activity.

IN WITNESS WHEREOF, I have hereunto set my hand this ___ day of ___, 20__ at _____, Philippines.

Bidder's Representative/Authorized Signatory

SUBSCRIBED AND SWORN to before me this ____ day of *[month]* *[year]* at *[place of execution]*, Philippines. Affiant/s is/are personally known to me and was/were identified by me through competent evidence of identity as defined in the 2004 Rules on Notarial Practice (A.M. No. 02-8-13-SC). Affiant/s exhibited to me his/her *[insert type of government identification card used]*, with his/her photograph and signature appearing thereon, with no. _____ and his/her Community Tax Certificate No. _____ issued on ____ at _____.

Witness my hand and seal this ____ day of *[month]* *[year]*.

NAME OF NOTARY PUBLIC

Serial No. of Commission _____

Notary Public for _____ until _____

Roll of Attorneys No. _____

PTR No. _____ *[date issued]*, *[place issued]*

IBP No. _____ *[date issued]*, *[place issued]*

Doc. No. _____

Page No. _____

Book No. _____

Series of _____

* This form will not apply for WB funded projects.

Bank Guarantee Form for Advance Payment

To: *[name and address of PROCURING ENTITY]*
[name of Contract]

Gentlemen and/or Ladies:

In accordance with the payment provision included in the Special Conditions of Contract, which amends Clause 10 of the General Conditions of Contract to provide for advance payment, *[name and address of Supplier]* (hereinafter called the “Supplier”) shall deposit with the PROCURING ENTITY a bank guarantee to guarantee its proper and faithful performance under the said Clause of the Contract in an amount of *[amount of guarantee in figures and words]*.

We, the *[bank or financial institution]*, as instructed by the Supplier, agree unconditionally and irrevocably to guarantee as primary obligator and not as surety merely, the payment to the PROCURING ENTITY on its first demand without whatsoever right of objection on our part and without its first claim to the Supplier, in the amount not exceeding *[amount of guarantee in figures and words]*.

We further agree that no change or addition to or other modification of the terms of the Contract to be performed thereunder or of any of the Contract documents which may be made between the PROCURING ENTITY and the Supplier, shall in any way release us from any liability under this guarantee, and we hereby waive notice of any such change, addition, or modification.

This guarantee shall remain valid and in full effect from the date of the advance payment received by the Supplier under the Contract until *[date]*.

Yours truly,

Signature and seal of the Guarantors

[name of bank or financial institution]

[address]

[date]

BID SECURING DECLARATION FORM

REPUBLIC OF THE PHILIPPINES)
CITY OF _____) S.S.

X-----X

BID SECURING DECLARATION **Invitation to Bid:***[Insert Reference number]*

To: *[Insert name and address of the Procuring Entity]*

I/We⁵, the undersigned, declare that:

1. I/We understand that, according to your conditions, bids must be supported by a Bid Security, which may be in the form of a Bid-Securing Declaration.
2. I/We accept that: (a) I/we will be automatically disqualified from bidding for any contract with any procuring entity for a period of two (2) years upon receipt of your Blacklisting order; and, (b) I/we will pay the applicable fine provided under Section 6 of the Guidelines on the Use of Bid Securing Declaration, within fifteen (15) days from receipt of the written demand by the procuring entity for the commission of acts resulting to the enforcement of the bid securing declaration under Sections 23.1(b), 34.2, 40.1 and 69.1, except 69.1(f), of the IRR of RA 9184; without prejudice to other legal action the government may undertake.
3. I/We understand that this BidSecuring Declaration shall cease to be valid on the following circumstances:
 - (a) Upon expiration of the bid validity period, or any extension thereof pursuant to your request;
 - (b) I am/we are declared ineligible or post-disqualified upon receipt of your notice to such effect, and (i) I/we failed to timely file a request for reconsideration or (ii) I/we filed a waiver to avail of said right;
 - (c) I am/we are declared the bidder with the Lowest Calculated Responsive Bid, and I/we have furnished the performance security and signed the Contract.

⁵ Select one and delete the other. Adopt the same instruction for similar terms throughout the document.

IN WITNESS WHEREOF, I/We have hereunto set my/our hand/s this ____ day of [month] [year] at [place of execution].

[Insert NAME OF BIDDER'S AUTHORIZED
REPRESENTATIVE]
[Insert Signatory's Legal Capacity]
Affiant

SUBSCRIBED AND SWORN to before me this ____ day of [month] [year] at [place of execution], Philippines. Affiant/s is/are personally known to me and was/were identified by me through competent evidence of identity as defined in the 2004 Rules on Notarial Practice (A.M. No. 02-8-13-SC). Affiant/s exhibited to me his/her [insert type of government identification card used], with his/her photograph and signature appearing thereon, with no. _____ and his/her Community Tax Certificate No. _____ issued on ____ at _____.

Witness my hand and seal this ____ day of [month] [year].

NAME OF NOTARY PUBLIC

Serial No. of Commission _____
Notary Public for _____ until _____
Roll of Attorneys No. _____
PTR No. _____ [date issued], [place issued]
IBP No. _____ [date issued], [place issued]

Doc. No. _____
Page No. _____
Book No. _____
Series of _____